

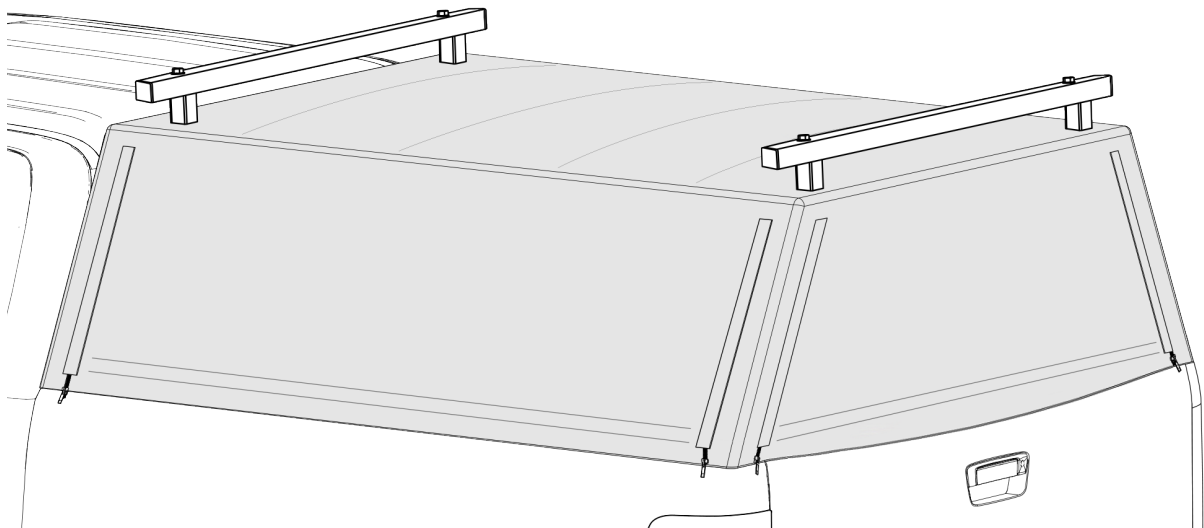

**TUFF
TONNEAUS**

TUFF CANOPY

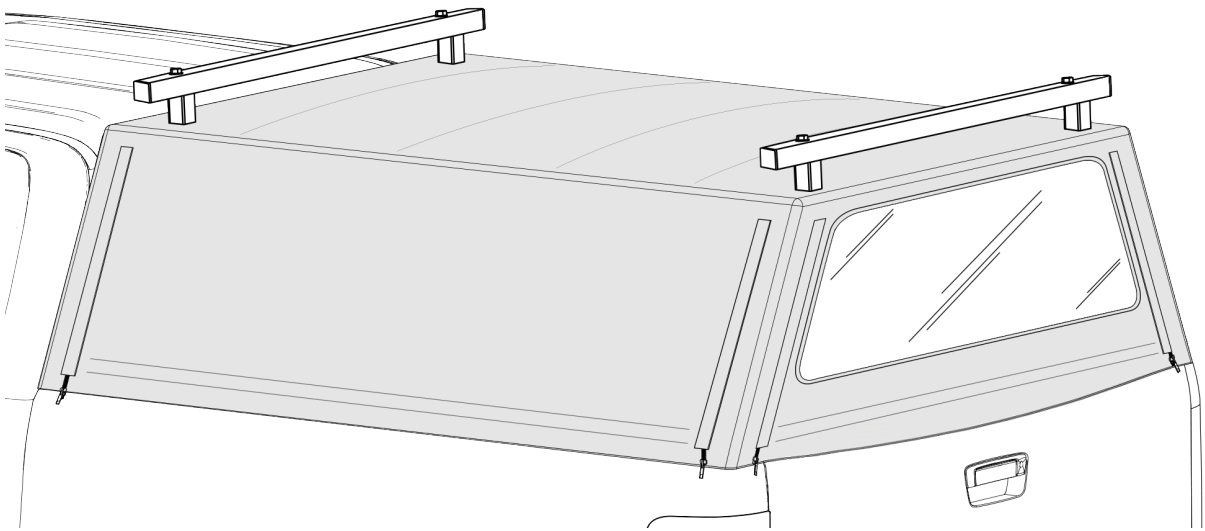

INSTALLATION INSTRUCTIONS

PART NO: TC11585 // PART DESCRIPTION: Ford Ranger PY DC, 2022 - Current, Tuff Canopy
 PART NO: TC11585T // PART DESCRIPTION: Window Option

IN THE BOX

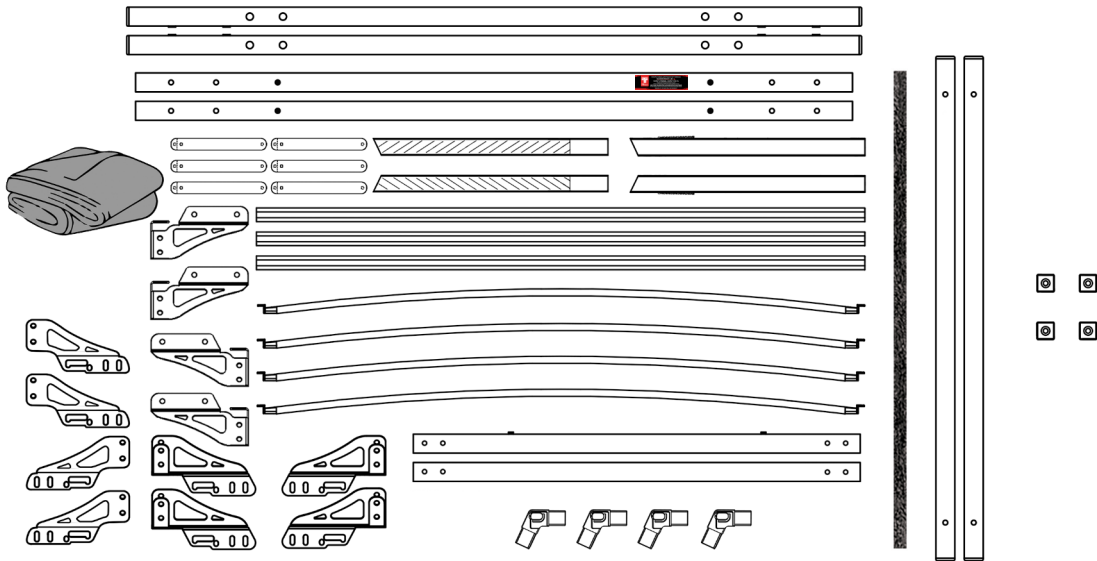

HARDWARE

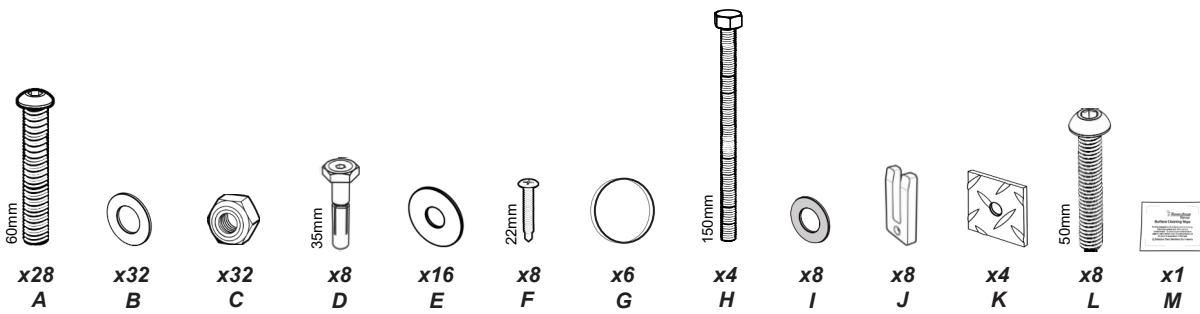

TOOLS REQUIRED

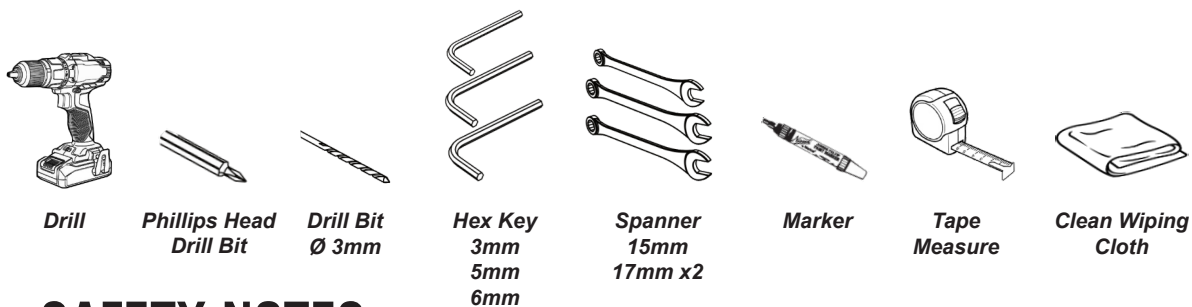

SAFETY NOTES

- Ensure that appropriate Personal Protective Equipment is used.
- During the accessory fitment, ensure all Australian automotive and dealership safety practices are followed.
- Always refer to the vehicles workshop manual when removing components.



GLOSSARY

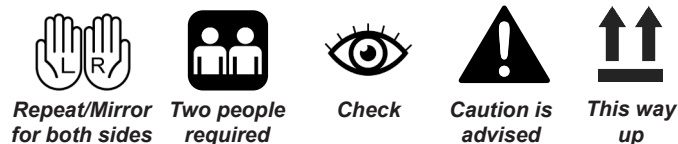

Any vehicle accessories which are not properly fitted, can be dangerous. Please read these instructions carefully prior to fitting and comply with the instructions at all times. If in any doubt, please contact us e: sales@tto.com.au

OVERVIEW

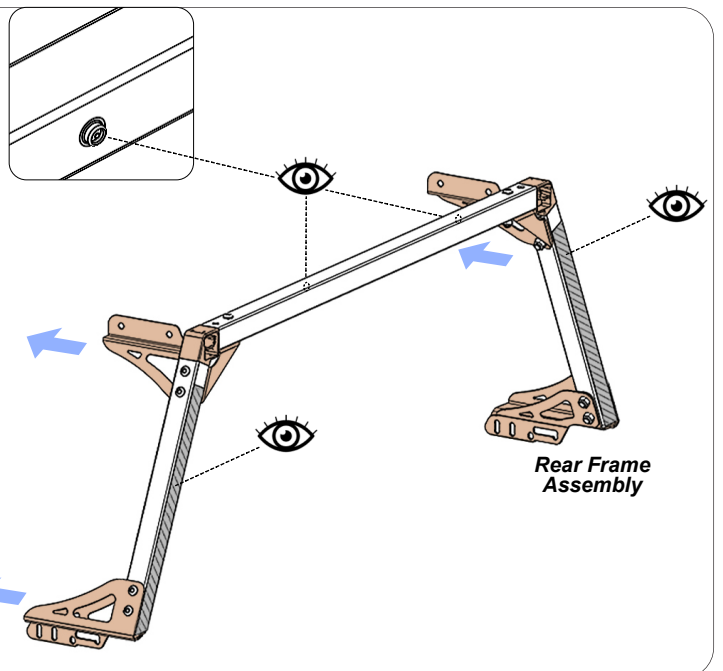
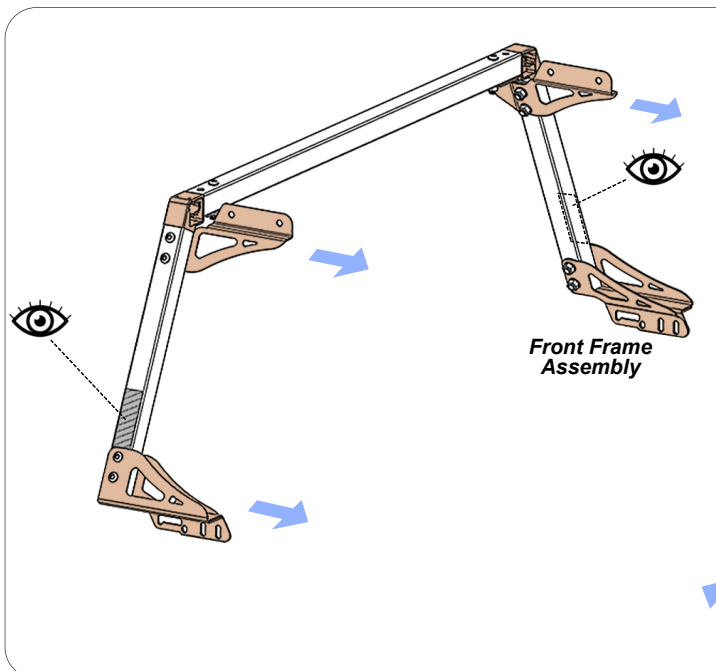
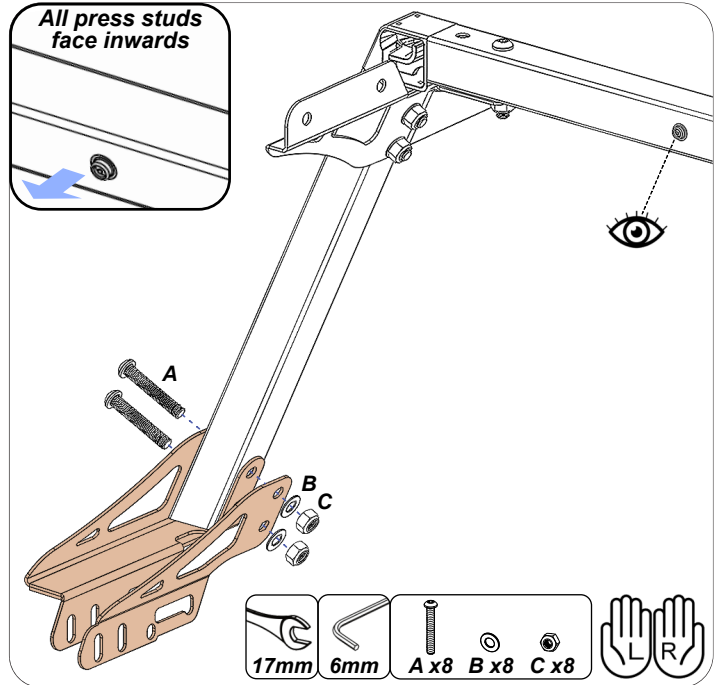
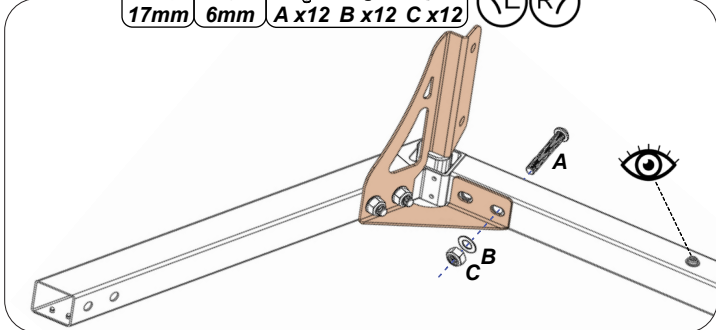
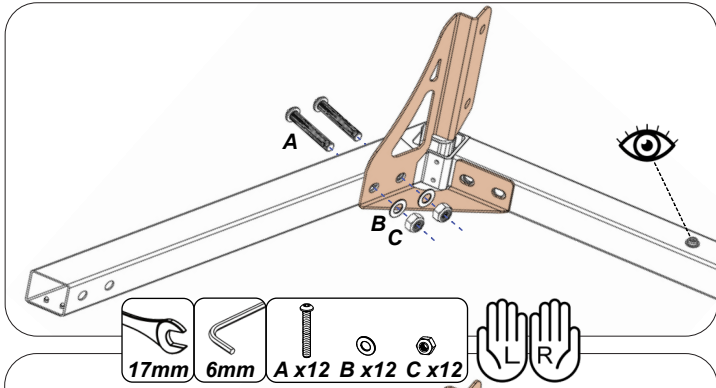
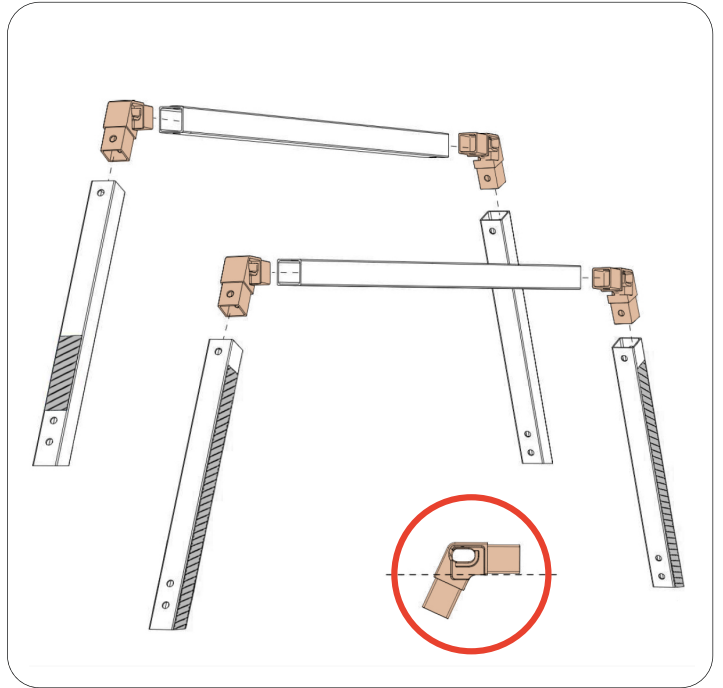
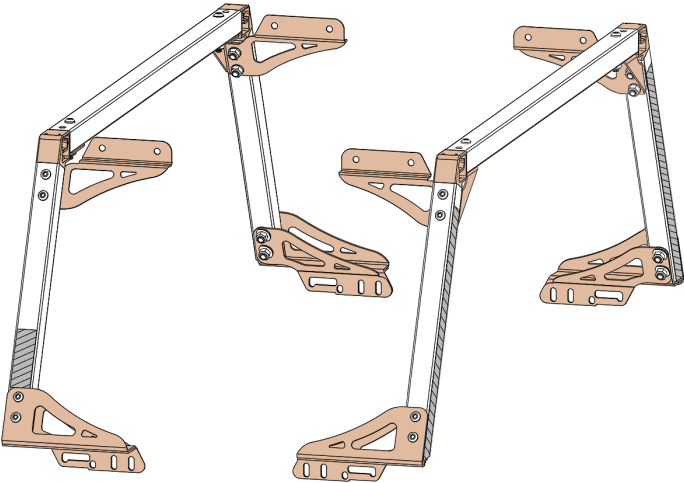

OVERVIEW

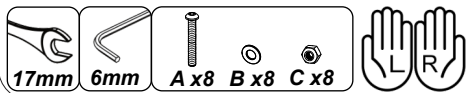
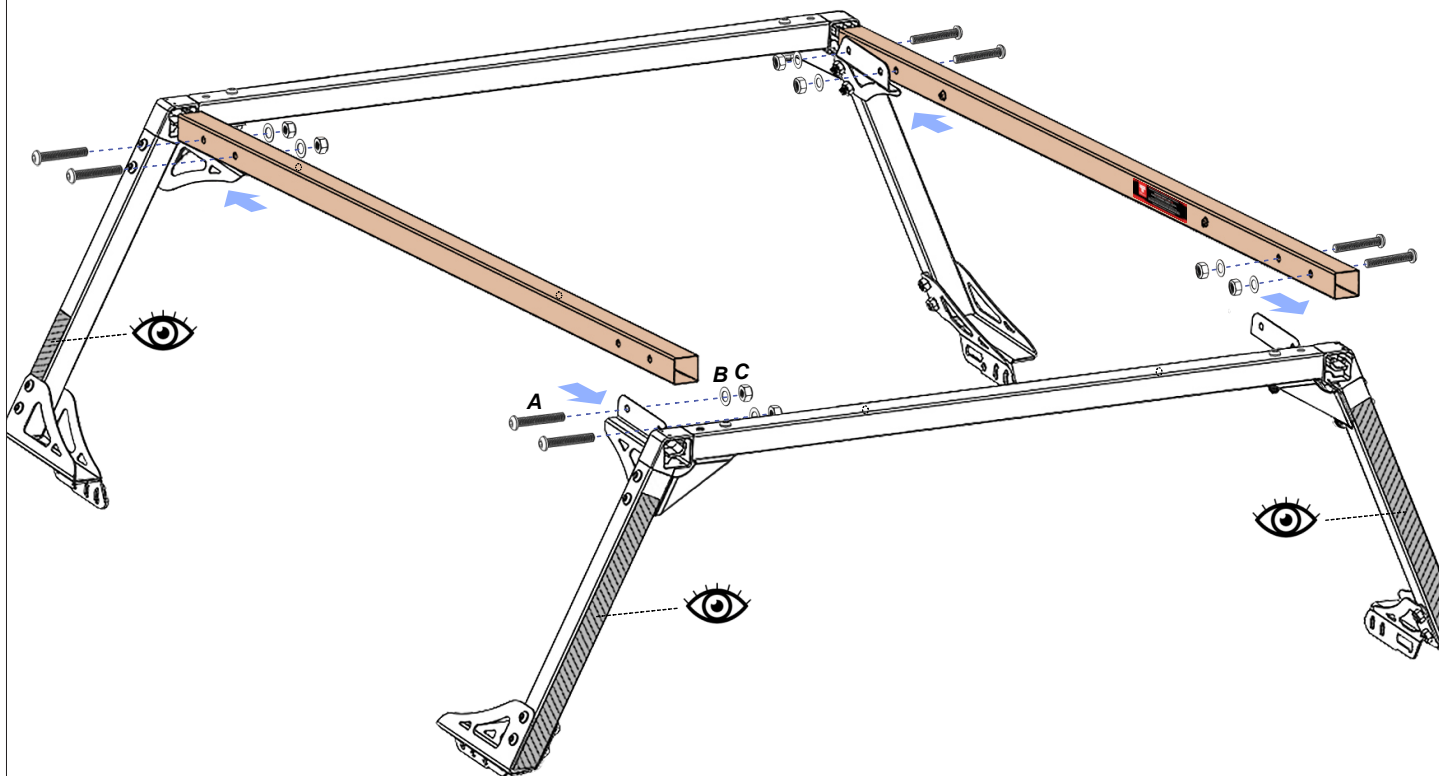
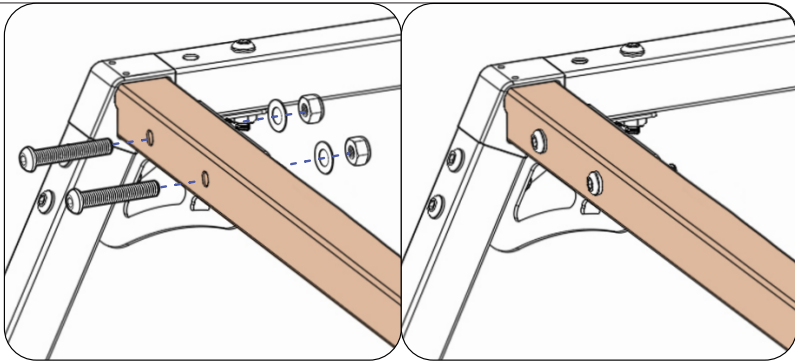
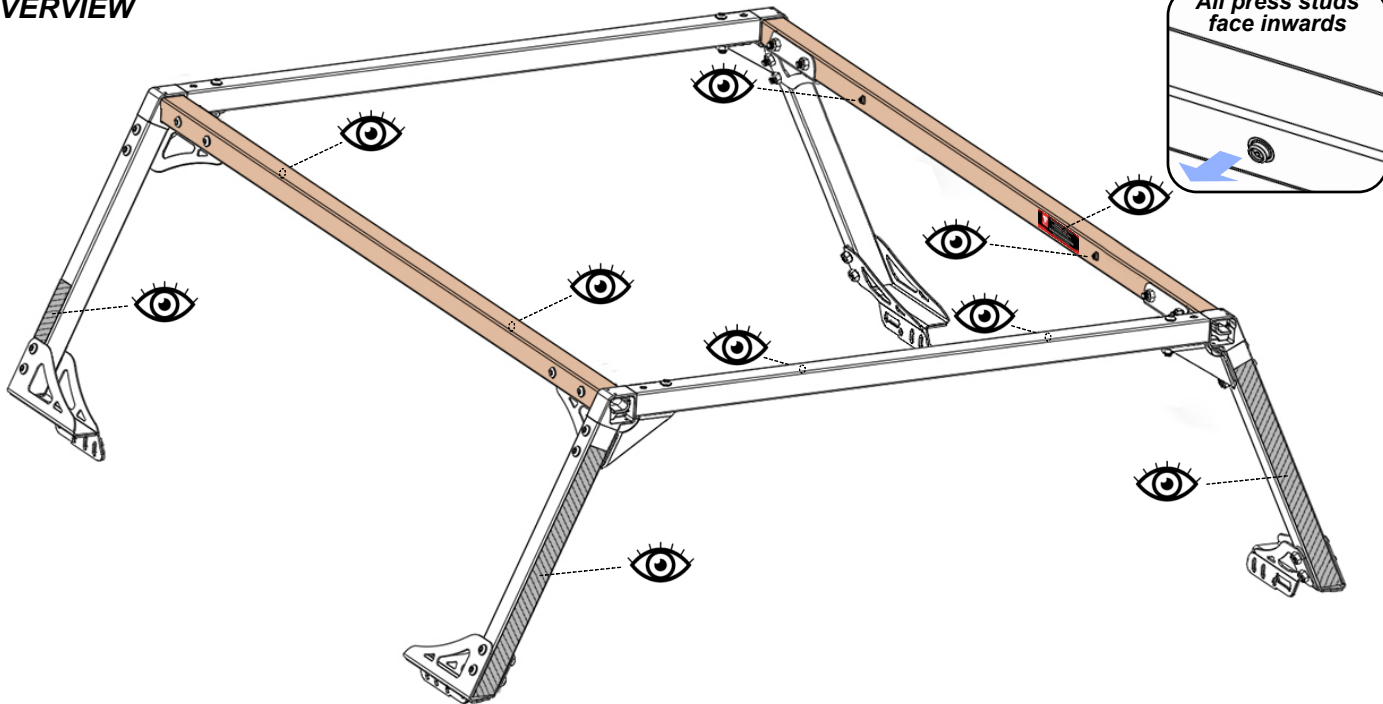

OVERVIEW

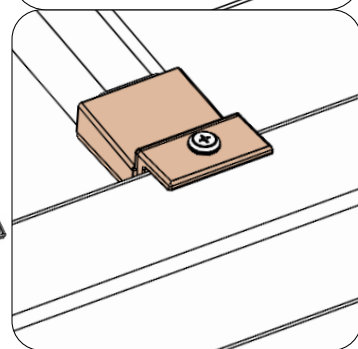
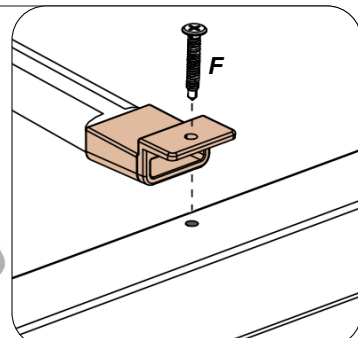
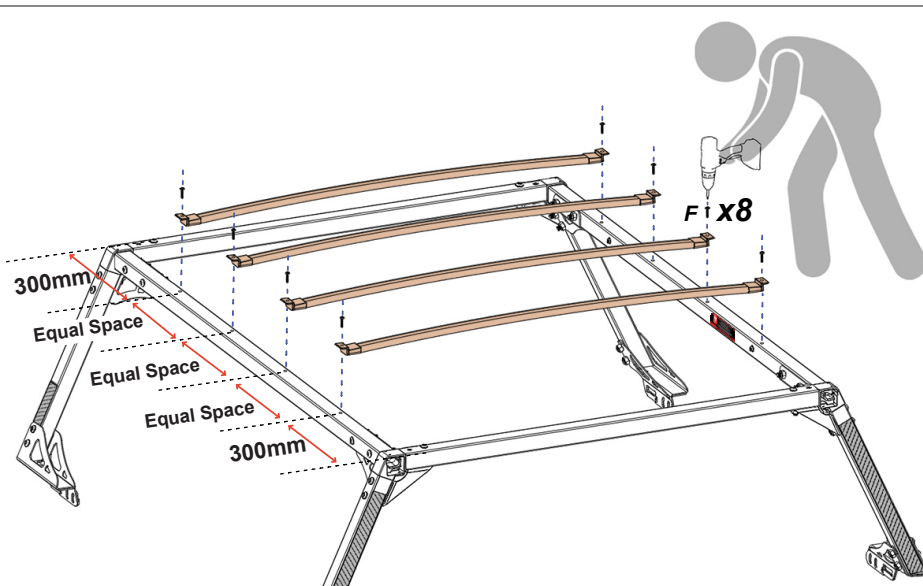
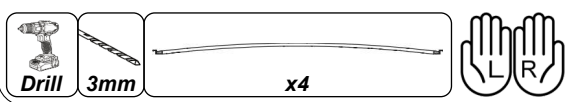
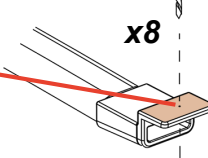
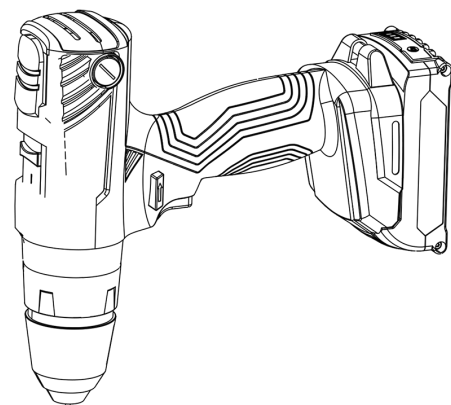
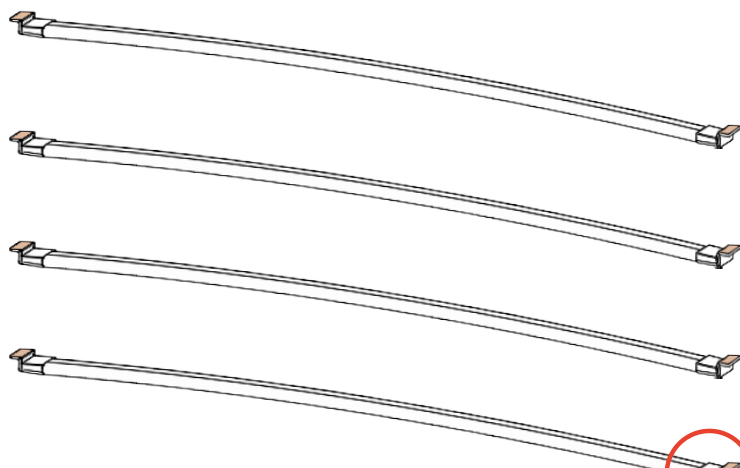
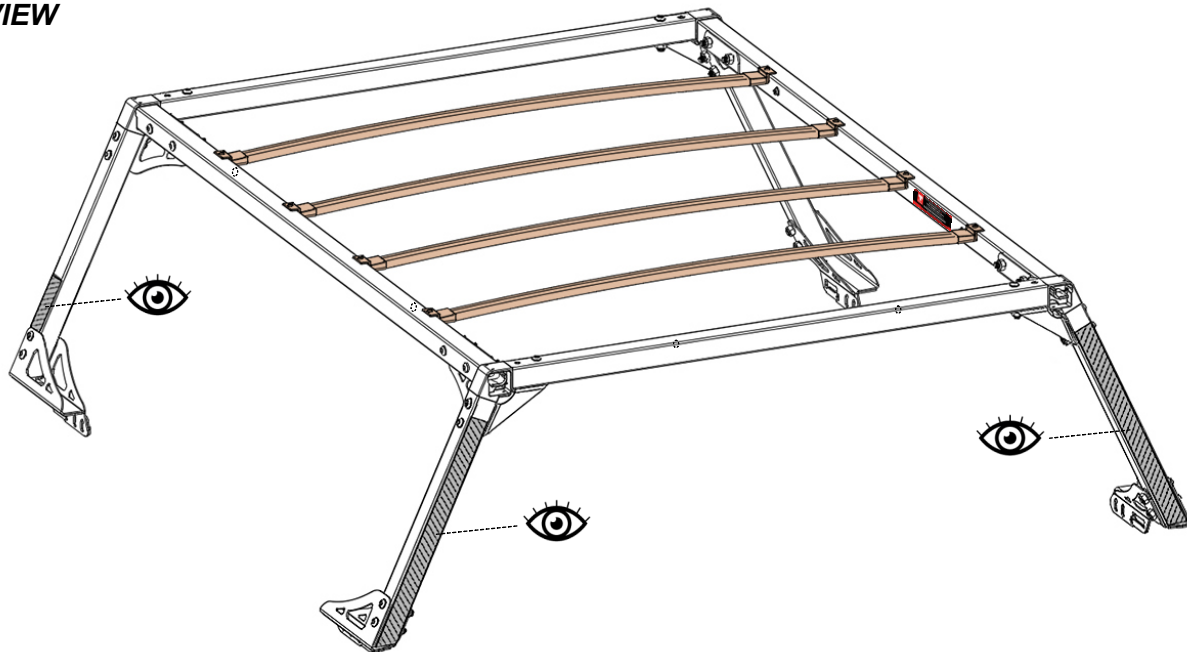

OVERVIEW

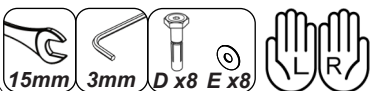
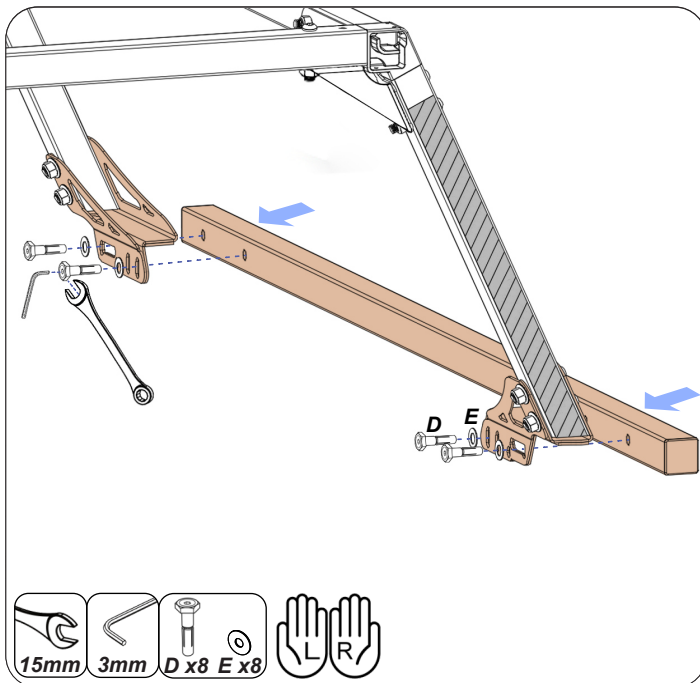
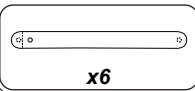
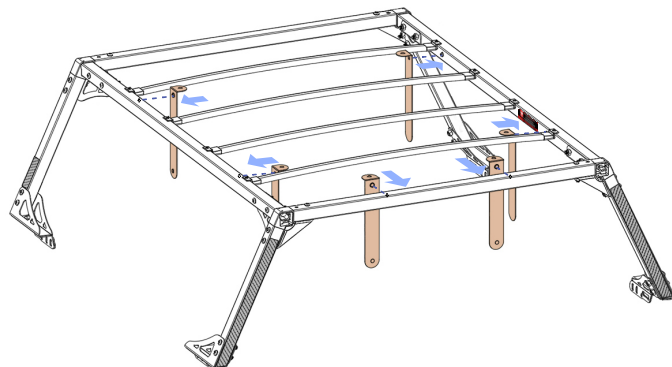
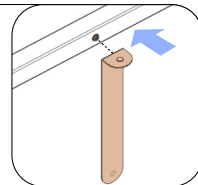
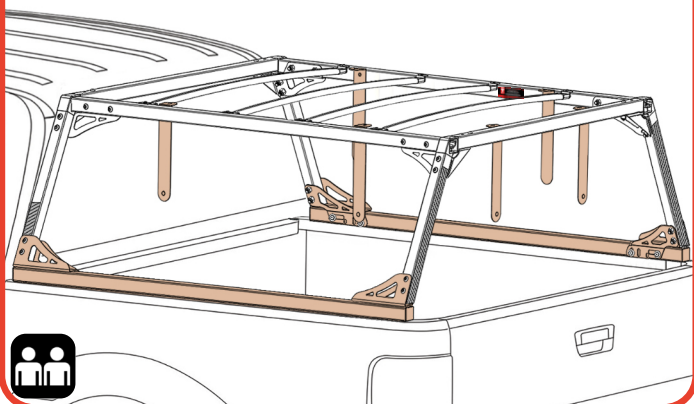

Remove the 4 plastic covers from each corner as shown below and store them away.

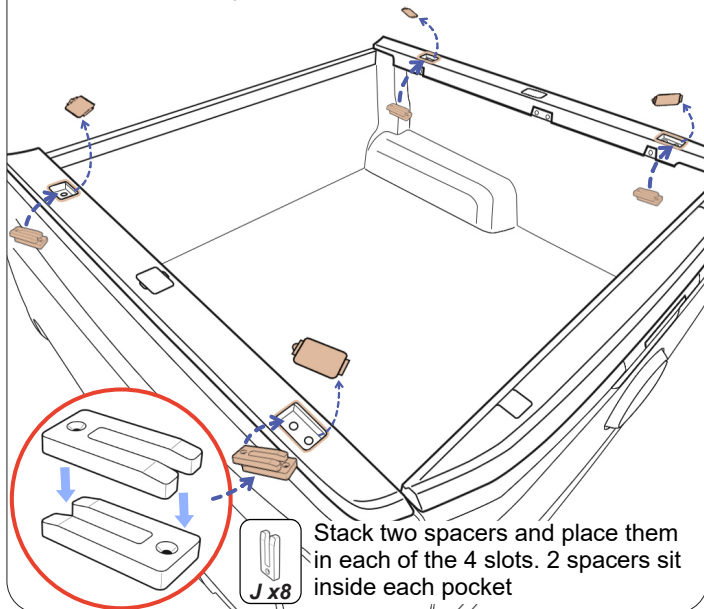

Stack two spacers and place them in each of the 4 slots. 2 spacers sit inside each pocket

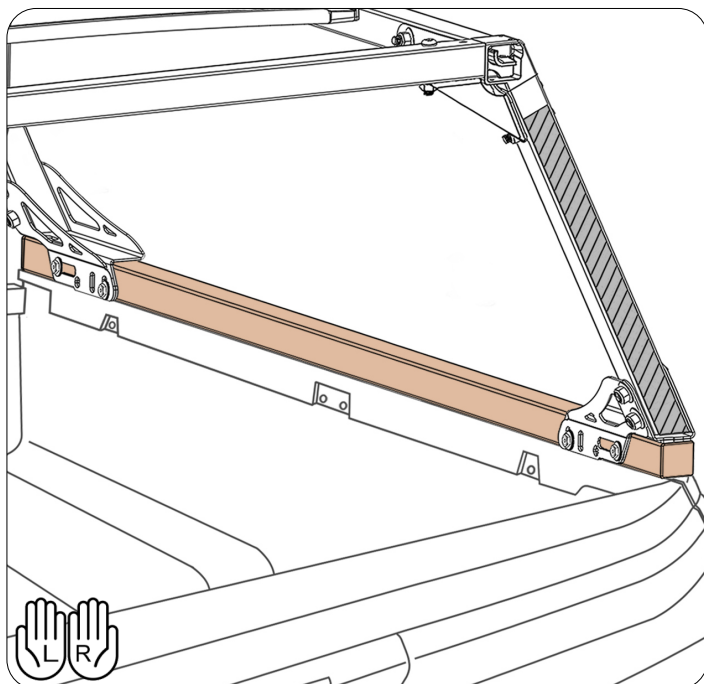
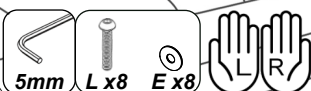
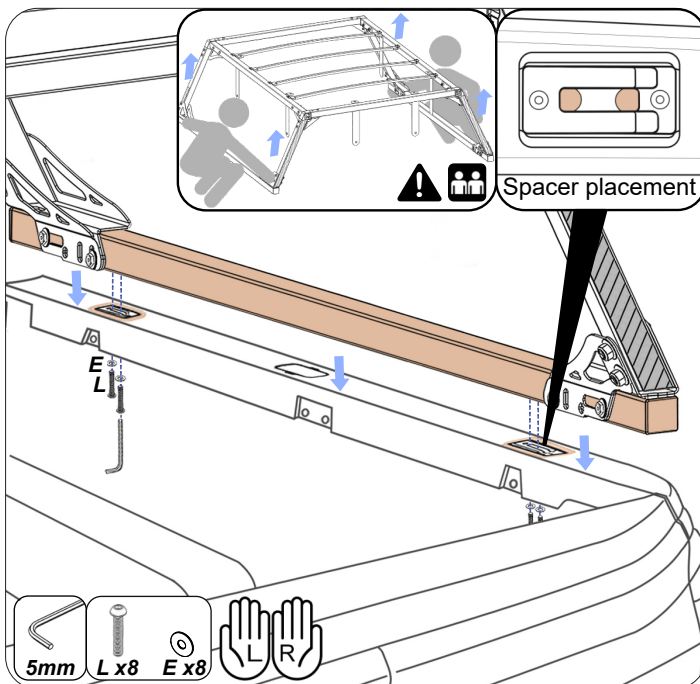

Refer to next page on how to attach front of canopy to front edge of tub.

❖ Ensure the canvas roof's seam lines match the frame's top edges, especially the front and back edges, since the roof is cut to the same length as the frame. Avoid overhang. This helps position the rack holes correctly. Adjust the cover as needed and secure it with the hook-and-loop velcro strips on the frame legs.

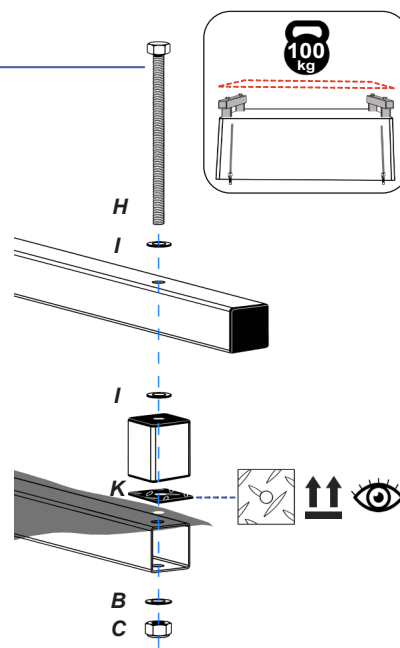
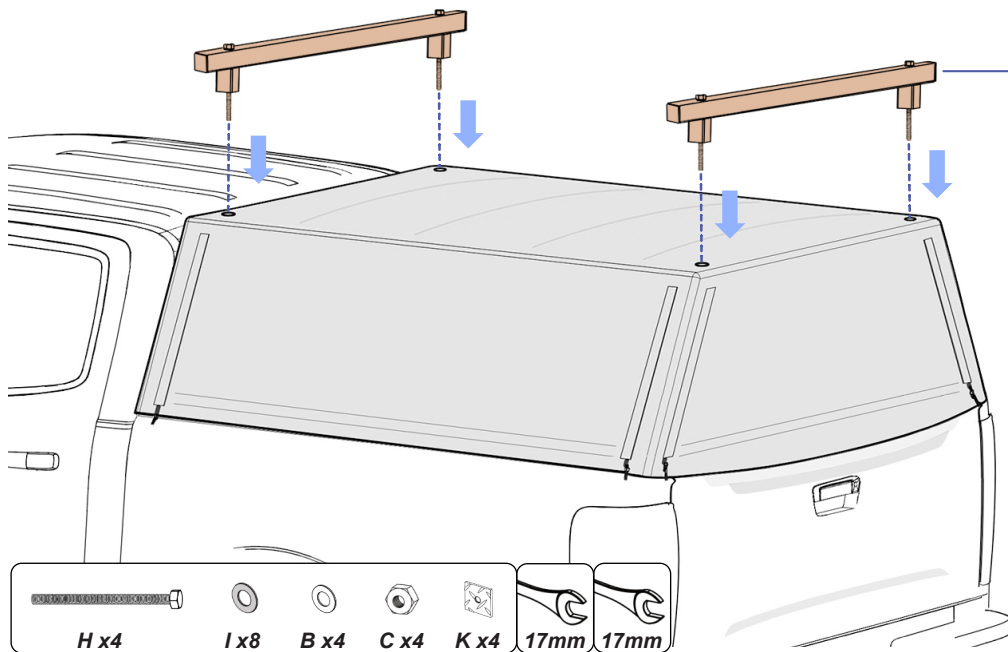
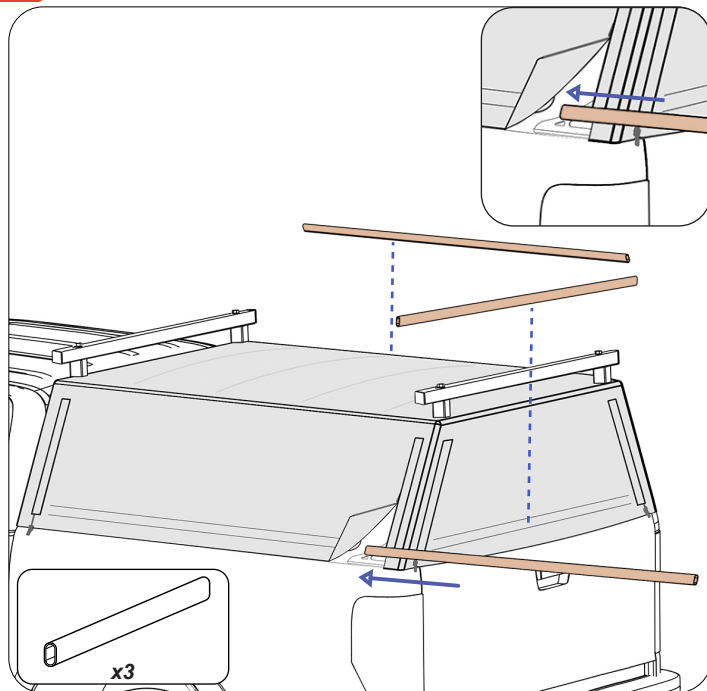
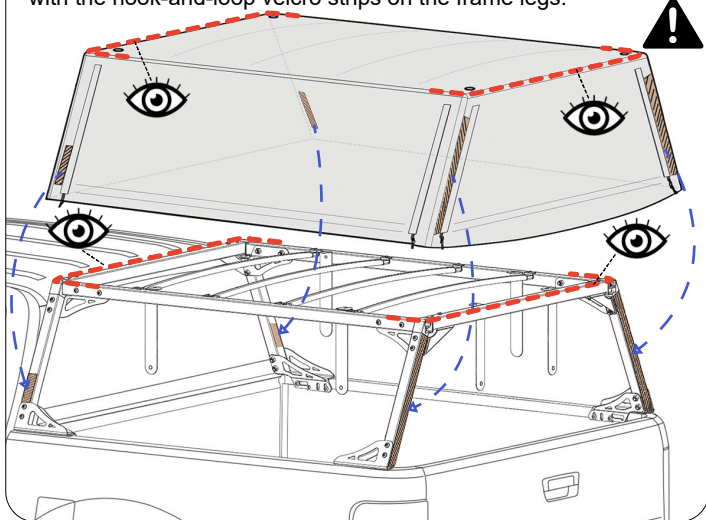

-  H x4
-  I x8
-  B x4
-  C x4
-  K x4
-  17mm
-  17mm

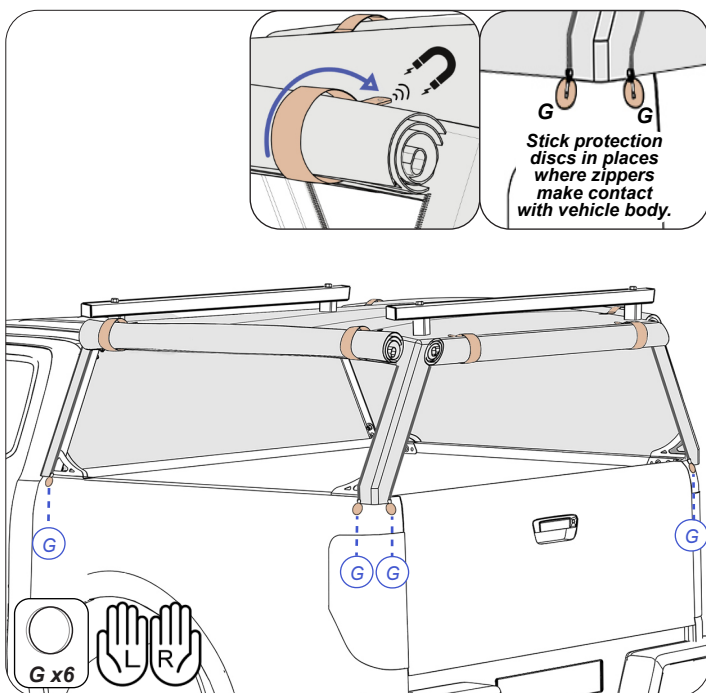

HOW TO ATTACH THE FRONT OF CANOPY TO TUB

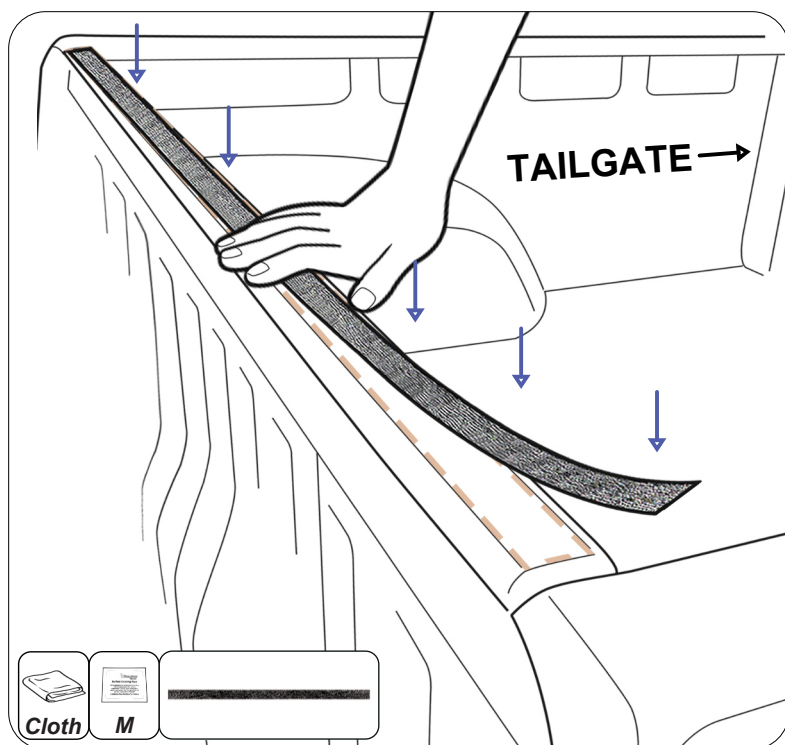

Clean any dust or dirt from top front edge of UTE tub with clean cloth and then wipe down with surface cleaning wipe. Let the surface dry. Then apply Velcro strip with **even firm pressure**. **Allow to cure for 24 hours for full bond strength.**

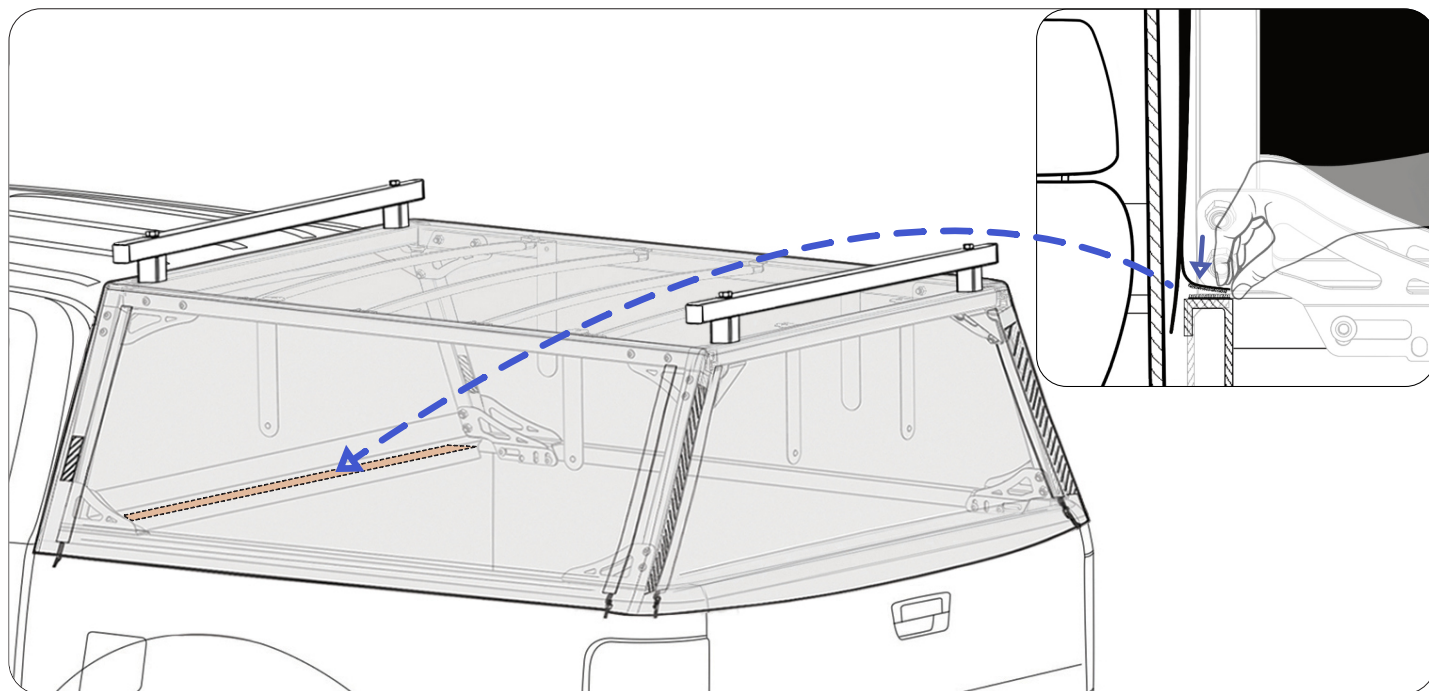



Send us a photo of your Tuff Canopy!
Happy with how your canopy turned out?
Please send us a photo to: sales@tto.com.au



INSTRUCTIONS FOR USE

Safety

- ❖ Ensure the canopy is completely closed before driving.
- ❖ Regularly check the tightness of the fasteners.
- ❖ Load must be evenly distributed on Ladder Racks and adequately secured.
- ❖ Do NOT exceed 100 kg Dynamic and 350 kg Static weight limit on Ladder Racks.

Load carrying Requirements and recommendations

- ❖ The load must be evenly distributed over the area of the Ladder Rack system, and the center of gravity of the load kept as low as possible. Loads which overhang the ends of the carrier system must conform to any relevant laws or by-laws in your area, and shall be adequately secured.
- ❖ Loads must be adequately secured using suitable straps or similar tightening and locking devices. The security of the load and roof load carrier shall be checked after loading and regularly throughout the journey. Elastic straps must not be used. The user is warned to maintain and to use straps in working order.
- ❖ It is recommended that items which may produce significant lifting forces (surfboard, sailboard, etc) are not carried side-by-side, but in such a way that lifting force is minimized, securing them independently to the front and rear of the vehicle using straps or other methods which are capable of withstanding the lifting forces. Elastic straps must not be used. Where specialized accessories are available to carry or secure loads, it is recommended that they are used.
- ❖ The handling characteristics of a vehicle (in particular crosswind sensitivity, handling on bends and braking) change when a carrier system is fitted and especially if that system is loaded. Driving techniques should be altered to allow for these changes, speed reduced, especially on bends, and braking distances made greater.



MAINTENANCE & CARE INSTRUCTIONS

Thank you for choosing a Tuff Tonneaus canopy for your vehicle! Our canopies are built to last, providing you with the durability and functionality you need. However, to ensure the longevity of your canopy, it is crucial that you follow these maintenance and care instructions carefully.

ZIPPERS

One key aspect of your canopy maintenance involves the zippers. Dust or dirt may accumulate in the zipper teeth over time, especially if you are frequently in dusty or sandy environments. If such accumulation occurs, please avoid forcing the zipper open or closed, as it may cause damage. Instead, it is recommended that you wash the zipper teeth gently to remove any lodged debris. If the debris is stubborn, use a gentle brush. Dry zippers after.

CANVAS

The premium canvas of your canopy also requires special care to maintain its physical performance and aesthetic lustre. In particular, the waterproof performance of the canvas can be improved through proper conditioning. To condition the canvas, start by fitting the canopy to your UTE. Then thoroughly wet the canvas with a garden hose, making sure to cover both the inside and the outside. Allow the canopy to fully dry, preferably in the sun. Repeat 2 or 3 more times. This allows the fabric to settle after transport and packaging.

The following key points will help maximise the durability and life of your canvas:

- ❖ To remove dirt, brush the fabric with a soft bristle brush. An occasional hosing may remove dust and some ingrained dirt.
- ❖ Never scrub the canvas fabric.
- ❖ Do not expose to petrol or oil.
- ❖ Immediately remove deposits of organic matter (such as soil, grass, bird droppings).
- ❖ Remove any mildew, as it appears, first by brushing, then by treating with diluted chlorine bleach (typically 1 part household grade bleach to 4 parts water to achieve 1% available chlorine). Allow to dry in the sun, then hose well to remove any residue.
- ❖ Do not use strong bleach such as 'pool chlorine'.
- ❖ Do not use soaps, detergents, solvents, or other liquid cleaners.

By following these instructions, you can extend the life of your canopy, maintain its aesthetic appeal, and enhance its functional performance. We want your experience with our product to be nothing short of exceptional, and your care in maintaining your canopy is a significant part of that. Thank you for your cooperation and enjoy your canopy!