

# TONNEAU FITTING INSTRUCTION

D22 Navara 4WD ST-R Dual Cab,

Oct 2009 – June 2015

**Part number: 325**

## Package includes

<input type="checkbox"/> 1 X Tonneau Cover	<input type="checkbox"/> 2 x Bar Brackets
<input type="checkbox"/> 1 x Tonneau Support Bar	<input type="checkbox"/> 26 x Rivets
<input type="checkbox"/> 3 x Aluminium Rope Track-461mm long ea.	<input type="checkbox"/> 1 x Lock Bracket
<input type="checkbox"/> 1 x Support Bar Sheath	<input type="checkbox"/> 14 x Rope Buttons
<input type="checkbox"/> 1 x Fitting Instructions	<input type="checkbox"/> 4 x Dowel
	<input type="checkbox"/> 14 x Anti Abrasive Discs

# 1. TONNEAU COVER FITTING

**NOTE** Read entire instructions prior to start.

## 1.1 BASIC TOOL REQUIRED

Drill, 4mm Drill Bit, Rivet Gun, Marking Pencil / Pen

## 1.2 TONNEAU COVER INSTALLATION PROCEDURE

1. Using two pieces of dowel, join the 3 aluminium rope tracks together. Place the other 2 pieces of dowel in the ends of the now joined rope track.
2. Rest the aluminium rope track on the side rails as Shown in Diagram A, and push forward to the vertical face of the tub.
3. Using a 4.5 mm drill bit, drill 6 holes 50mm from the end of each of the aluminium rope tracks into the front of tub.
4. Once all the holes have been drilled, remove the dowelling pieces. Squeeze silicon along the back of the rope tracks and pop rivet into place.
5. Place the bar bracket 725mm rear from the inside edge of the front of the tub and 12mm up from the bottom lip, drill and rivet in place.
6. Slide the front of the tonneau cover through the aluminium rope track section.
7. Neatly lay tonneau out over support bar and tub in the installed position. Fasten all collars around sports bar legs with the press studs.
8. To fit the rope buttons to the tailgate, mark two vertical lines just below the form line on the Tailgate, 65mm and 482mm in from the RHS edge of the Tailgate. Align the top edge of the Buttons with the lower edge of the form line, and the centre of the Button hole with the vertical lines. Once in position use the button as a guide and drill a 4.5mm hole through the Tailgate.

Repeat Step 8. for the LHS

9. To fit rope buttons to the sides, mark vertical lines just below the form line, 50 mm, 392 mm, 736 mm, 1084 mm, 1429 mm from the front edge of the tub on the LHS.
10. Align the top edge of the Button with the lower edge of the form line, and the centre of the Button holes with the vertical lines.
11. Once in position use the button as a guide and drill 4.5 mm holes through the sheet metal.
12. Attach the Buttons to the Tub, using the 4 mm rivets.
13. To Fit Anti-Abrasive Discs: Firstly clean the area behind each bunji head with a clean rag and methyated sprits. Then attach the anti-abrasive discs centrally behind each bunji head.

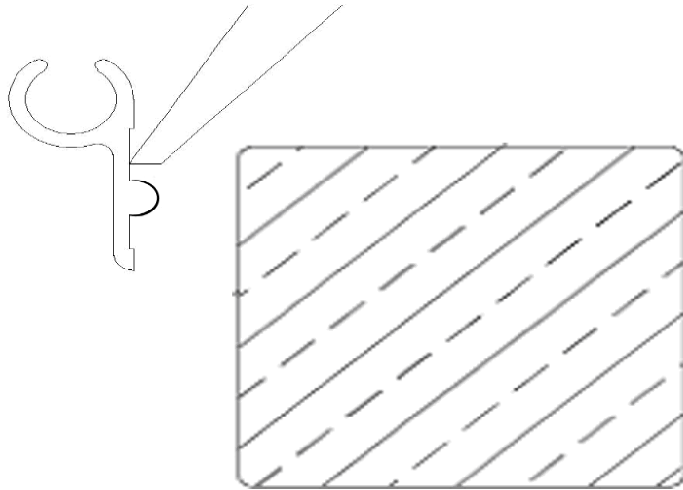

*Figure 1*

Placement of aluminium rope track. Ensure channel is above the tub's top edge.

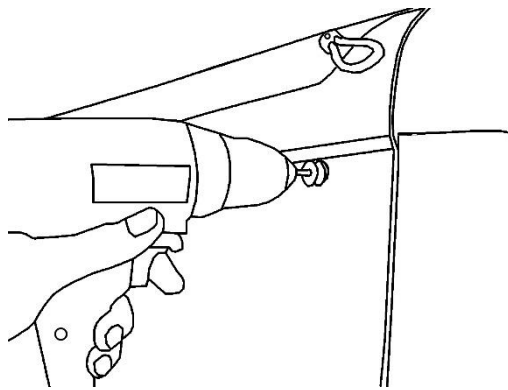

*Figure 2*

Placement of rope button is on tailgate panel crease as per measurements.

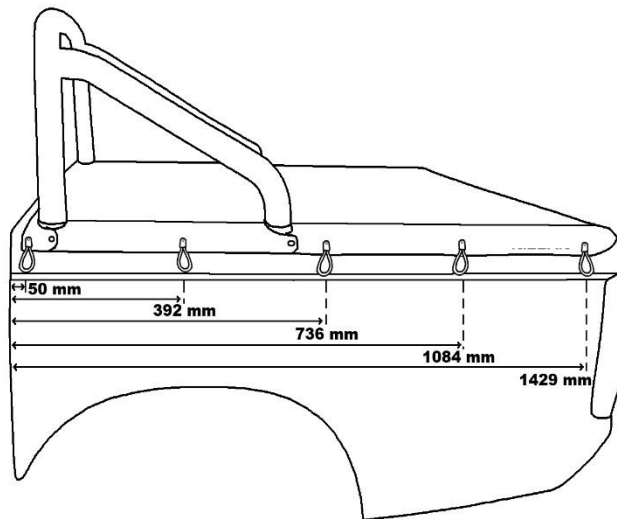

*Figure 3*

Placement of rope button is on the side, is under panel crease as per measurements.

## 2. TONNO LOCK

The Tonno Lock is now a standard feature included with all Tuff Tonneaus. The Tonno Lock is situated at the front of the tonneau cover, so as not to impede the accessibility of the Tuff Tonneau.

Fitting the lock is simple and only requires a small attachment on the inside edge of the tub behind the cab. Together with a padlock, it provides you with an extremely effective theft deterrent. The Tonno Lock is designed to suit

all utes and prevent thieves stealing your Tuff Tonneau, so you can continue to rely on the Tuff Tonneaus' name to give you what you want in a tonneau cover.



### 2.1 BASIC TOOL REQUIRED

Rivet gun, Drill, Torch, and Marking Pencil/Pen.

You will need to buy a small Padlock- make sure the padlock will go through the hole on the Tonno lock.

### 2.2 TONNO LOCK CONTENTS

- 2 X 4MM Aluminium rivets
- 1 x Tonno Lock bracket

### 2.3 FITTING TONNO LOCK

1. Attach the black lock bracket to the bracket on the tonneau with your padlock, and fit the tarp.
2. Getting under the tarp with a torch, place the lock bracket against the body and mark holes with a pen.
3. Remove tonneau and drill the marks with a 4 mm drill bit, place the lock bracket in position and rivet.

## 3. MULTI-FIT SUPPORT BAR

The Tuff Tonneau Multi - Fit Support Bar is designed to fit almost all Utes on the Market, from Subaru Brumbys to Cab Chassis aluminium trays.



### 3.1 BASIC TOOL REQUIRED

Drill, 4mm drill bit

### 3.2 MULTI-FIT SUPPORT BAR CONTENTS

- 1 x hollow bar centrepiece
- 2 x grub screws
- 2 x solid bar end piece
- 1 x Tonneau bar sheath

### 3.3 FITTING MULTI-FIT BAR

1. Insert solid bar pieces into either end of hollow tube. Adjust bar so it fits between bar bracket holders with the holes facing to the ground (so the grub screws don't rub against the tonneau), as shown above and then with a white pencil make a mark through the small holes of the hollow bar onto the solid ends. This is where you will drill a hole to the depth of about 1-2mm (do not go any further)
2. Join the pieces back together and screw grub screws through the hollow bar into the holes that you drilled. **Make sure you do not over tighten the grub screws**. Then place the tonneau sheath over the bar to stop the bar wearing against the tonneau. Refit the bar. You may kink the bar in the middle to give it some extra height to assist with water runoff.

**Warning if you do not fit the tonneau sheath over the bar, the tonneau cover will quickly wear through which is not covered by warranty.**

## 4. WARRANTY AND FEEDBACK

**Please register your warranty details online at:**

**QR Code:**



**Website Link:**

**<http://www.tto.com.au/en-au/warranty.html>**

**Please complete our 2 minute feedback section as we strive to constantly improve for our customers.**

**Your Tuff Tonneau is now ready for work.**