

TONNEAU FITTING INSTRUCTION

Ford PX Ranger Dual Cab

Nov 2011-Current

Part number: 142SB

Package includes

1 X Tonneau cover	2 x Bar Brackets
1 x Tonneau Support Bar	24 x Rivets
1 x Support Bar Sheath	1 x Lock Bracket
1 x Fitting Instructions	18 x Rope Buttons
	1 x Rust Inhibitor
	18 x Anti Abrasive Discs

1. TONNEAU COVER FITTING

NOTE Read entire instructions prior to start.

1.1 BASIC TOOL REQUIRED

Drill, 4.5mm Drill Bit, Rivet Gun, Non-Permanent Pen

1.2 TONNEAU COVER INSTALLATION PROCEDURE

1. Mark a position 720mm from the inside edge of the tailgate of tub towards the front. Centrally locate the bar bracket over this position and the top edge of the bracket 5mm down from the top lip of the tub and drill and rivet bracket into place.. Repeat for other side of tub.

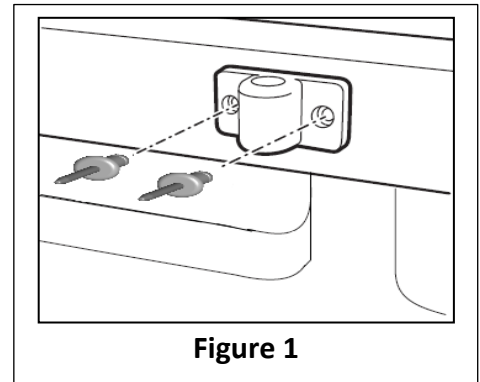

Figure 1

2. Fit tonneau support bar to bar brackets, using instruction over page.

3. Fit the front of the Tonneau Cover to the front of the Ute tub placing the Plastic Retainers (Fitted on the Tonneau Cover) on to the Metal Lip on the Body, between the cabin and the Ute Body. (Behind rear windscreen).

4. Fit buttons to the tailgate

- (a) Measure 465mm up from the bottom edge of the tailgate and mark button positions in line with each of the bunjis.
- (b) Working from the centre out: drill holes, apply rust inhibitor and rivet buttons into place. Attach bunjis to buttons as they are riveted in place.

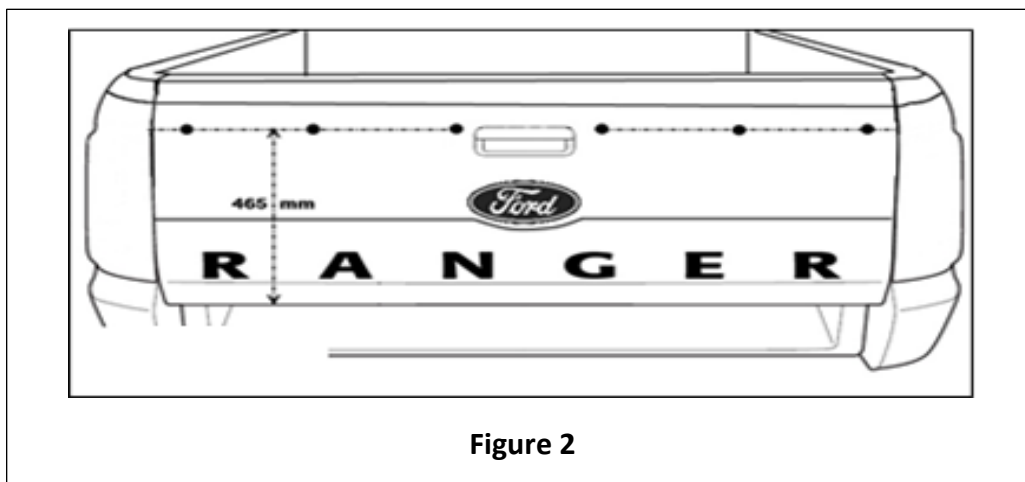

Figure 2

5. Fit buttons to side of Tub.

Measure down 165mm from the inside edge of the tub, and back 50mm from the front outside edge of the tub and mark. **This is the position of the front button.**

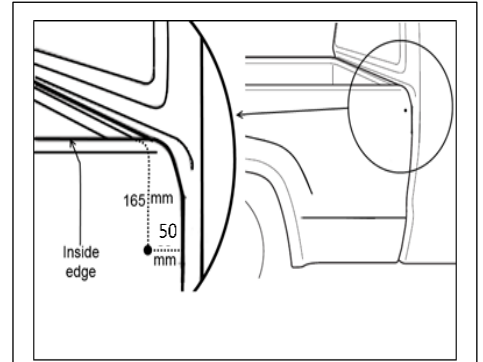

Figure 3

6. Measure down **155mm** from the inside edge of the tub, and forward **10mm** from the front outside edge of the taillight and mark.

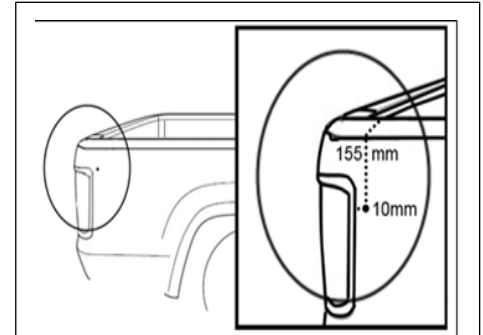

Figure 4

7. Using a straight edge or string line, draw a line between front mark & rear mark as shown in

Fit the **front button only** to the vehicle by drilling a 4mm hole at the front mark then apply rust inhibitor and rivet button into place.

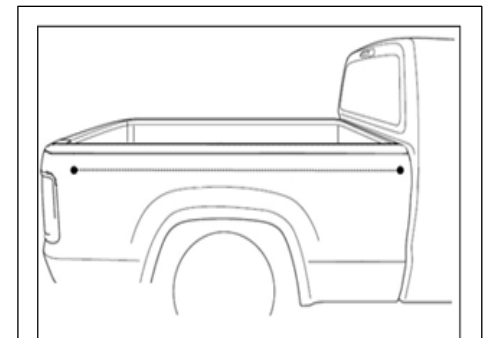

Figure 5

8. Work from the rear most bunjis towards the front, alternating from side to side. Line up the rear most bunji loop (#1) on the drivers side of the vehicle and make a mark on the line drawn in step 8. Drill hole, apply rust inhibitor and rivet button into place as shown in **Figure 6**

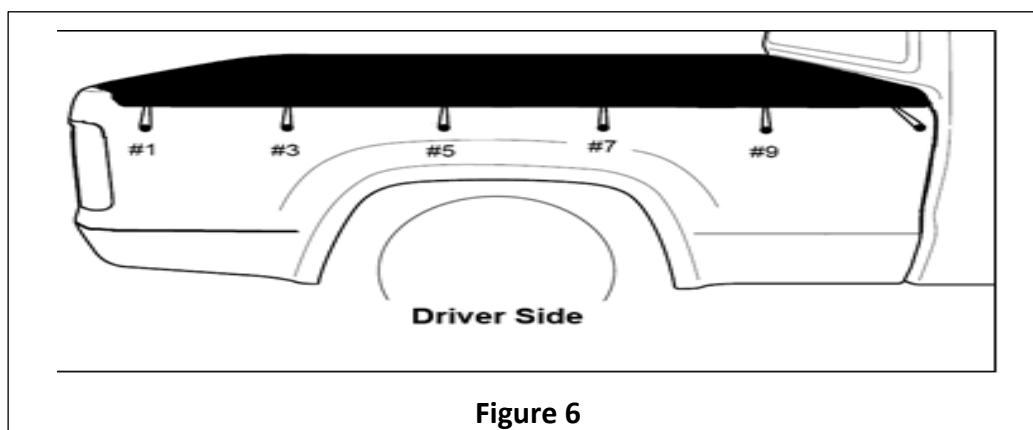
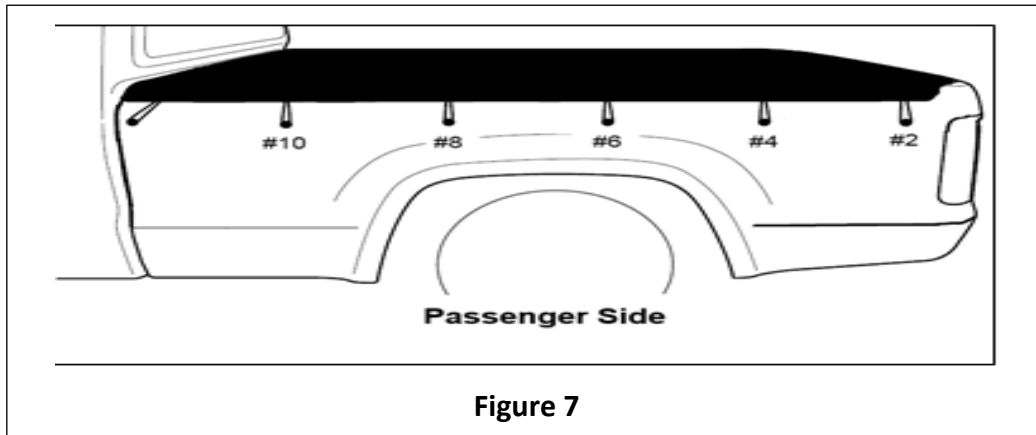

Figure 6

9. Repeat step 8 for the rear most bunji loop (#2) on the passenger side of the vehicle.

Fit remaining 8 bunjis following the sequence as in **Figures 6 & 7**



10. To Fit Anti-Abrasive Discs: Firstly clean the area behind each bunji head with a clean rag and methylated sprits. Then attach the anti-abrasive discs centrally behind each bunji head.

Note: Ensure you work from side to side to maintain tension across the tonneau cover.

2. TONNO LOCK

The Tonno Lock is now a standard feature included with all Tuff Tonneaus. The Tonno Lock is situated at the front of the tonneau cover, so as not to impede the accessibility of the Tuff Tonneau.

Fitting the lock is simple and only requires a small attachment on the inside edge of the tub behind the cab. Together with a padlock, it provides you with an extremely effective theft deterrent. The Tonno Lock is designed to suit all utes and prevent thieves stealing your Tuff Tonneau, so you can continue to rely on the Tuff Tonneaus' name to give you what you want in a tonneau cover.

2.1 BASIC TOOLS REQUIRED

Rivet gun, Drill, Torch, and Marking Pencil/Pen.

You will need to buy a small Padlock- make sure the padlock will go through the hole on the Tonno lock.

2.2 TONNO LOCK CONTENTS

- 2 X 4MM Aluminium rivets
- 1 x Tonno Lock bracket

2.3 FITTING TONNO LOCK

1. Attach the lock bracket to the bracket on the tonneau with your padlock, and fit the tarp.
2. Getting under the tarp with a torch, place the lock bracket against the body and mark holes with a pen.
3. Remove tonneau and drill the marks with a 4 mm drill bit, place the lock bracket in position and rivet.

3. MULTI-FIT SUPPORT BAR

The Tuff Tonneau Multi - Fit Support Bar is designed to fit almost all Utes on the Market, from Suburu Brumbys to Cab Chassis aluminium trays.

3.1 BASIC TOOLS REQUIRED

Drill, 4mm drill bit

3.2 MULTI-FIT SUPPORT BAR CONTENTS

- 1 x hollow bar centrepiece
- 2 x grub screws
- 2 x solid bar end piece
- 1 x Tonneau bar sheath

3.3 FITTING MULTI-FIT BAR

1. Insert solid bar pieces into either end of hollow tube. Adjust bar so it fits between bar bracket holders with the holes facing to the ground (so the grub screws don't rub against the tonneau), as shown above and then with a white pencil make a mark through the small holes of the hollow bar onto the solid ends. This is where you will drill a hole to the depth of about 1-2mm (do not go any further)
2. Join the pieces back together and screw grub screws through the hollow bar into the holes that you drilled. **Make sure you do not over tighten the grub screws.** Then place the tonneau sheath over the bar to stop the bar wearing against the tonneau. Refit the bar. You may kink the bar in the middle to give it some extra height to assist with water runoff.

Warning if you do not fit the tonneau sheath over the bar, the tonneau cover will quickly wear through which is not covered by warranty.

4. WARRANTY AND FEEDBACK

Please register your warranty details online at:

QR Code:



Website Link:

<http://www.tto.com.au/en-au/warranty.html>

Please complete our 2 minute feedback section as we strive to constantly improve for
our customers.

Your Tuff Tonneau is now ready for work.