



BYD SHARK 6

Clip On 2.0 Tonneau Cover

INSTALLATION GUIDE

Part Number: 11789

PARTS SUPPLIED

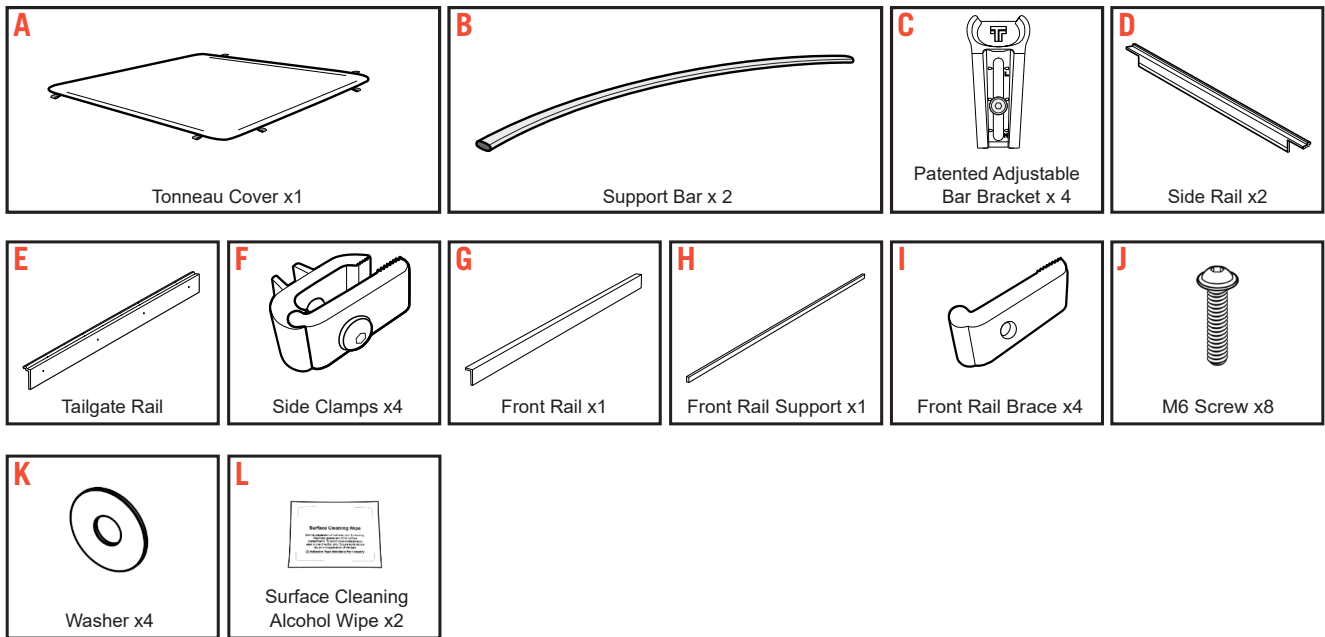

SAFETY NOTES

- Ensure that appropriate Personal Protective Equipment is used.
- During the accessory fitment, ensure all Australian automotive and dealership safety practices are followed.
- Always refer to vehicle's workshop manual when removing components.



FINAL ASSEMBLY

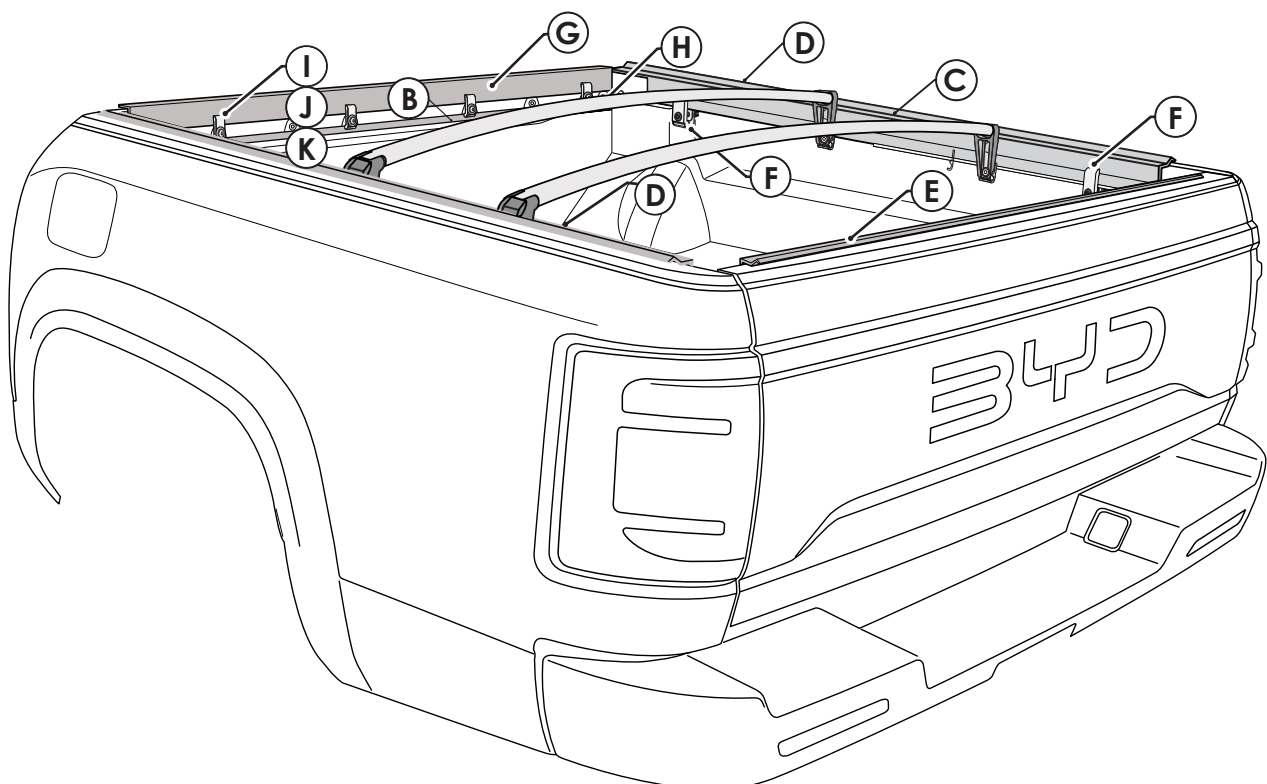

1

ASSEMBLING THE BAR BRACKET

STEP 1

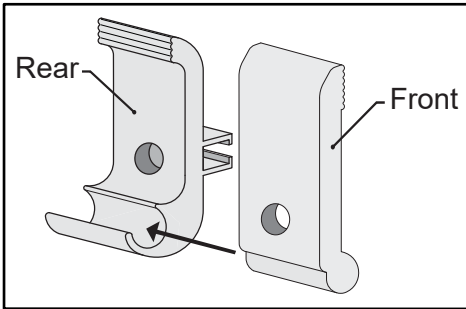

- Slide the Front and Rear Clamps together.

STEP 2

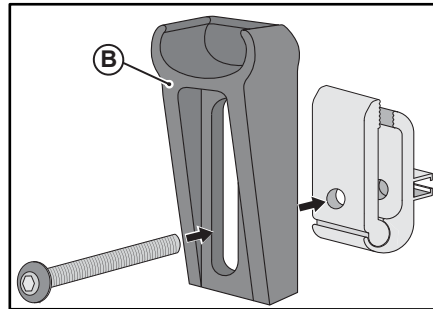

- Attach the Clamp to the Patented Adjustable Bar Bracket as shown.

STEP 3

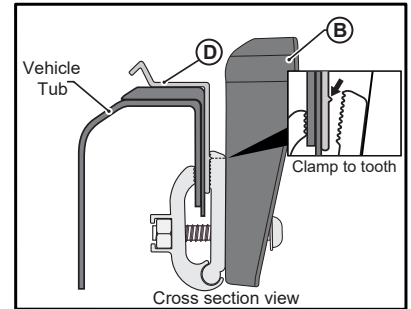

- Engage the now assembled Bar Bracket & Clamp to the Side Rails in the next steps.

2

ATTACH SIDE RAILS

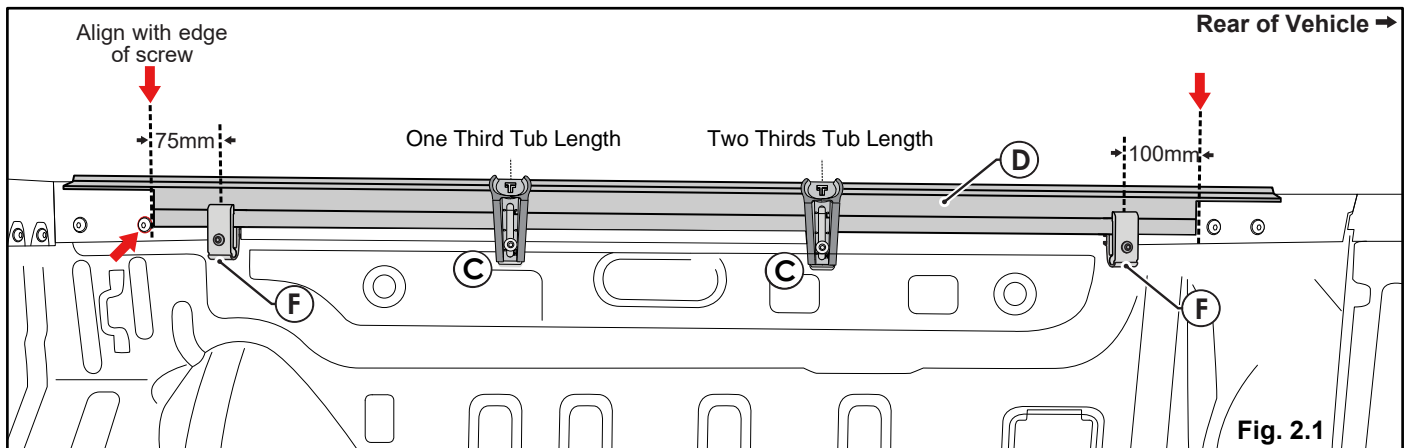

- Place the Side Rail (D) flush with the factory screw shown.
- Attach first Clamp (F) at 75mm from front edge of Side Rail (D) as shown above in Fig. 2.1. Attach second Clamp (F) 100mm from rear edge of Side Rail. Then attach the Bar Brackets (C) 1/3 and 2/3 down the tub, as shown above.
- Tighten bracket and clamps in place using appropriate tool.
- Repeat for the LHS Side Rail.

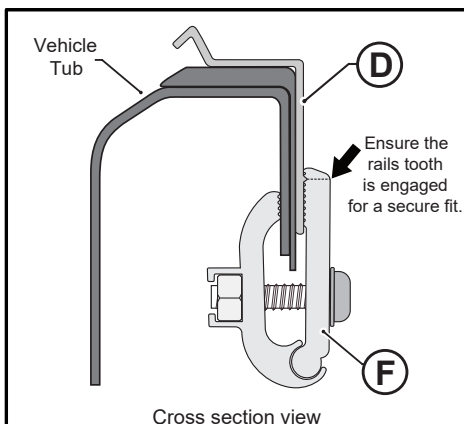

Important  For a flush fit the 3 centre bolts should be removed from tub wall before fitting rails.

Important  The side clamp needs to engage with the side aluminium rail tooth for a secure fit.

3

FIT THE FRONT RAIL SUPPORT

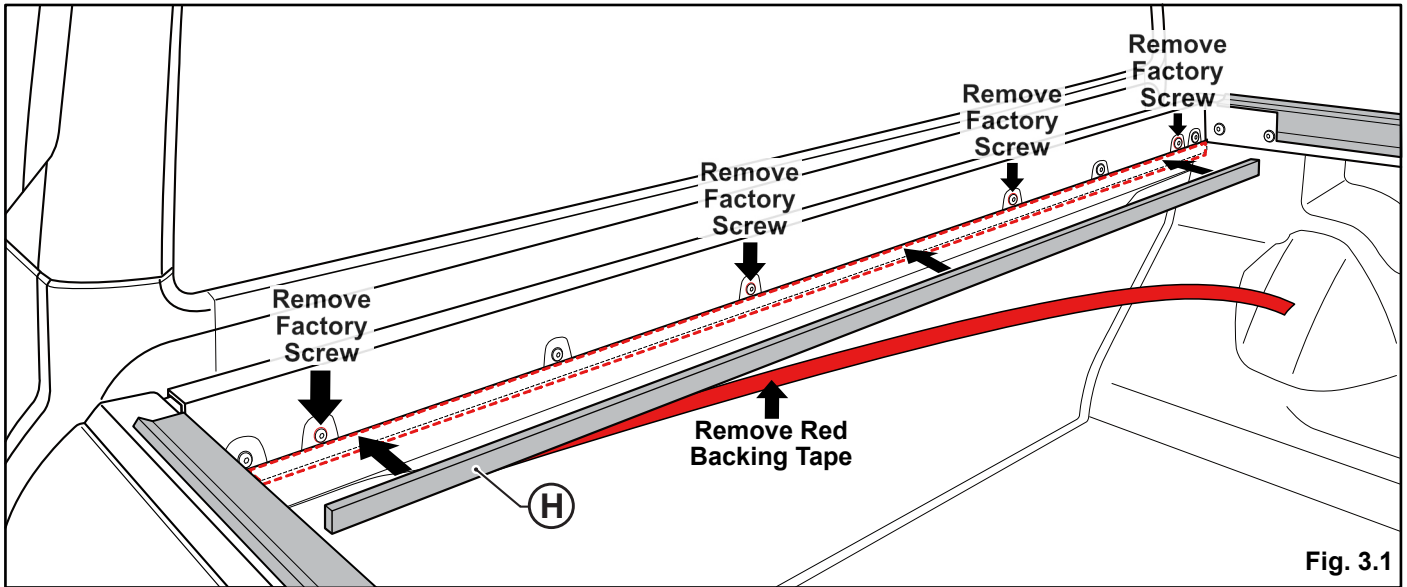

Fig. 3.1

- Wipe the dotted section shown in Fig. 3.1 with Surface Cleaning Alcohol Wipe (L).
- Remove red backing tape from the Front Rail Support (H) and stick it flush under the plastic trim as shown in Fig. 3.1
- Then remove the 4 factory screws marked above.

4

FIT THE FRONT RAIL

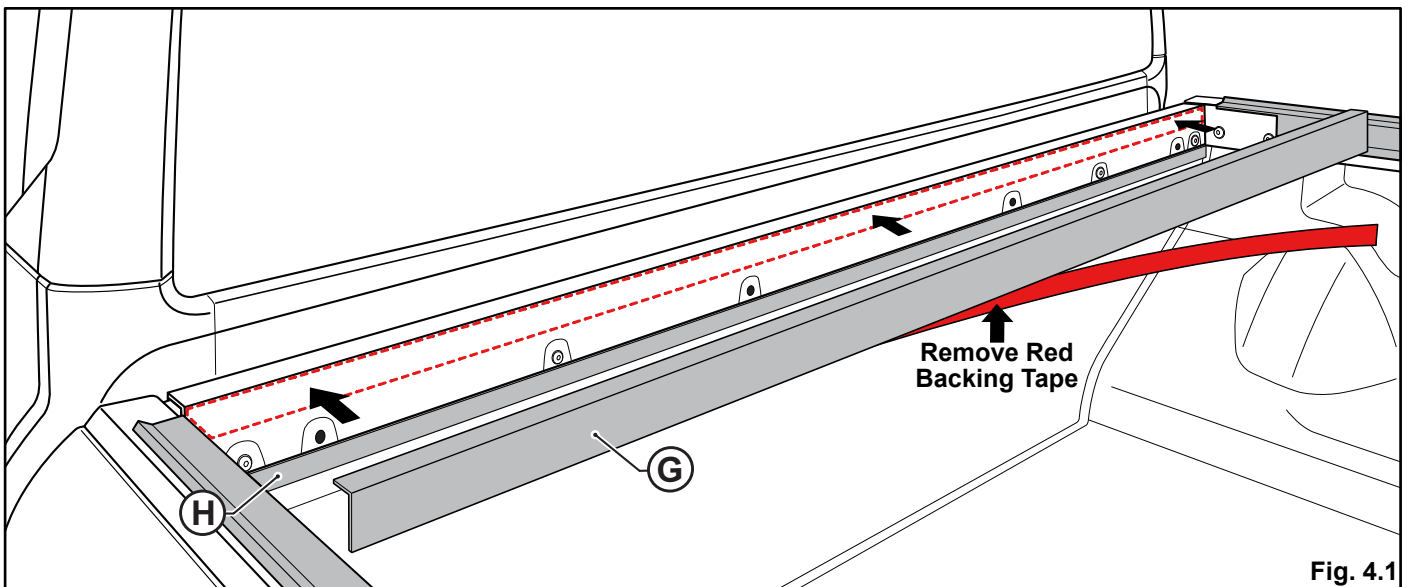

Fig. 4.1

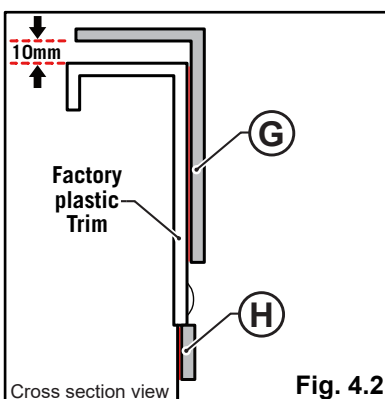

Fig. 4.2

- Wipe the dotted section shown in Fig. 4.1 with Surface Cleaning Alcohol Wipe (L).
- Align and mark the section to stick on the Front Rail. Remove red backing tape and carefully stick the Front Rail (G), leaving a 10mm gap as shown in Fig. 4.2

5 FIT FRONT RAIL BRACES

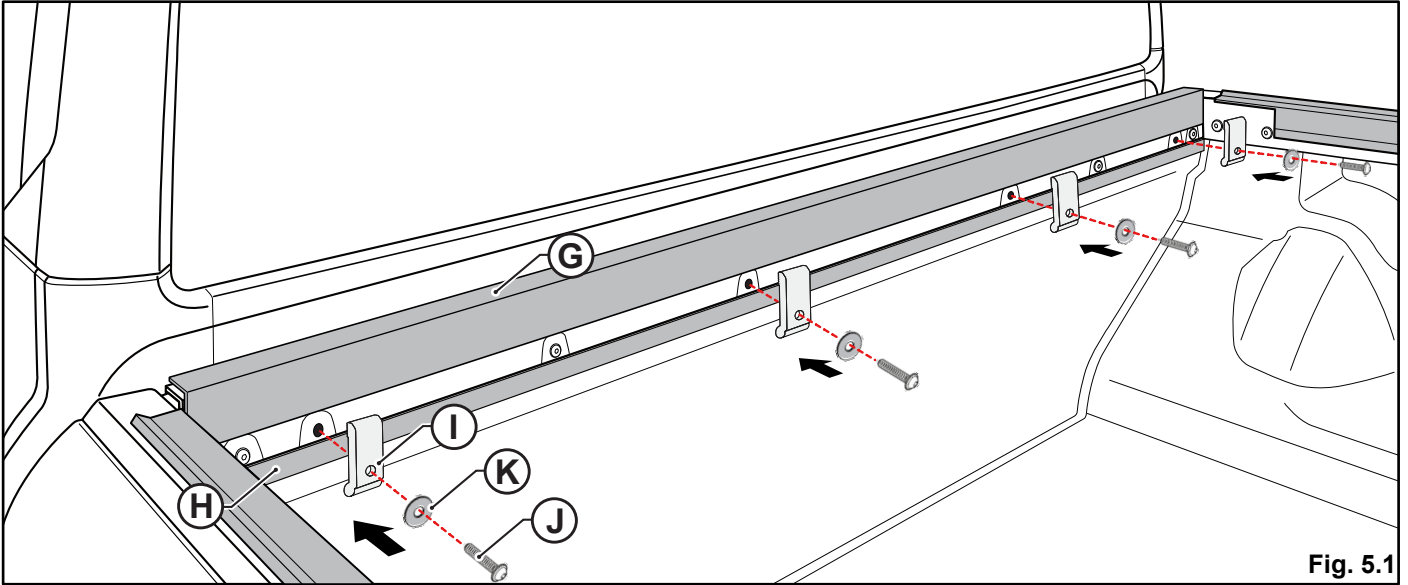

Fig. 5.1

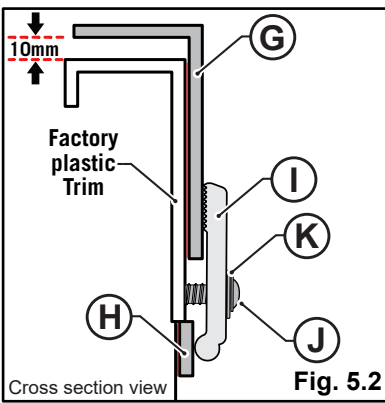
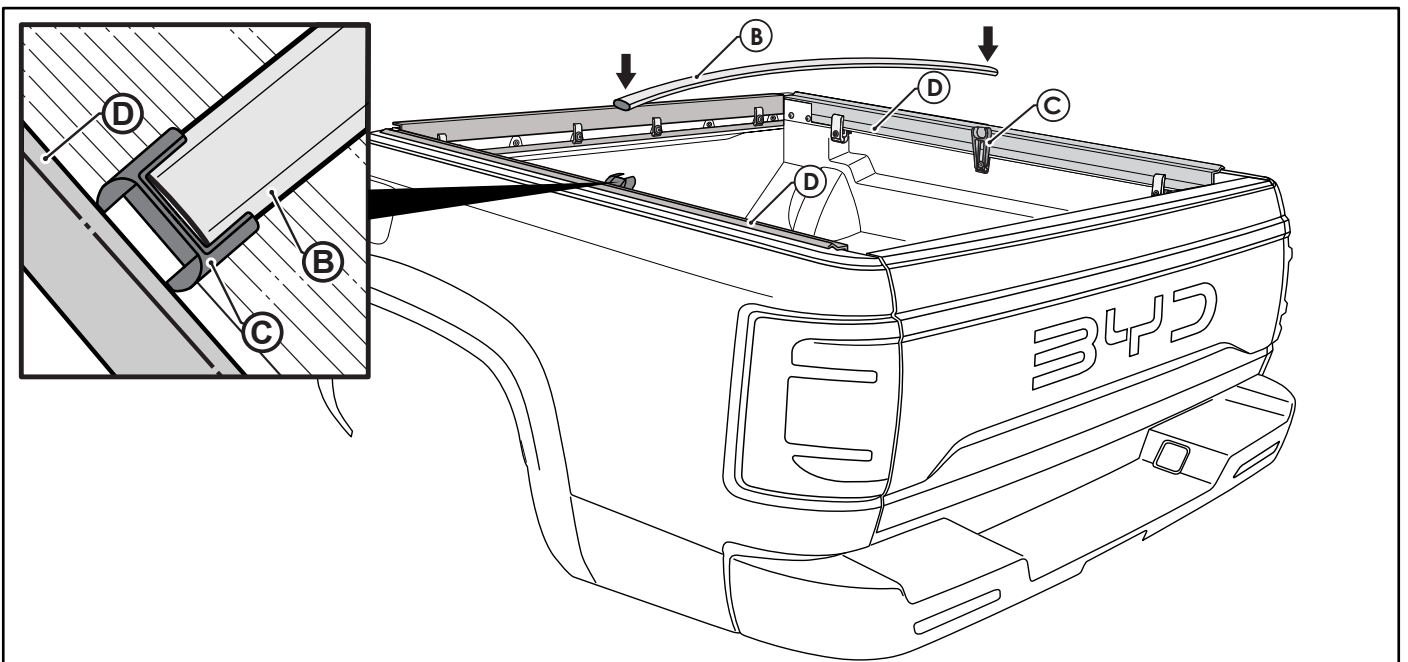

Fig. 5.2

- Attach the 4 Front Rail Braces ① using the M6 Screws ② and Washers ③ to where the 4 factory screws were previously removed in Step 3, Fig. 3.1.

6 FIT THE SUPPORT BAR



- Rotate the support Bars ④ 90° and push into the top of the Adjustable Bar Bracket ⑤.
- Ensure it is seated firmly into place by pushing lightly in the center of the Support Bar ④.

7 FIT THE TAILGATE RAIL

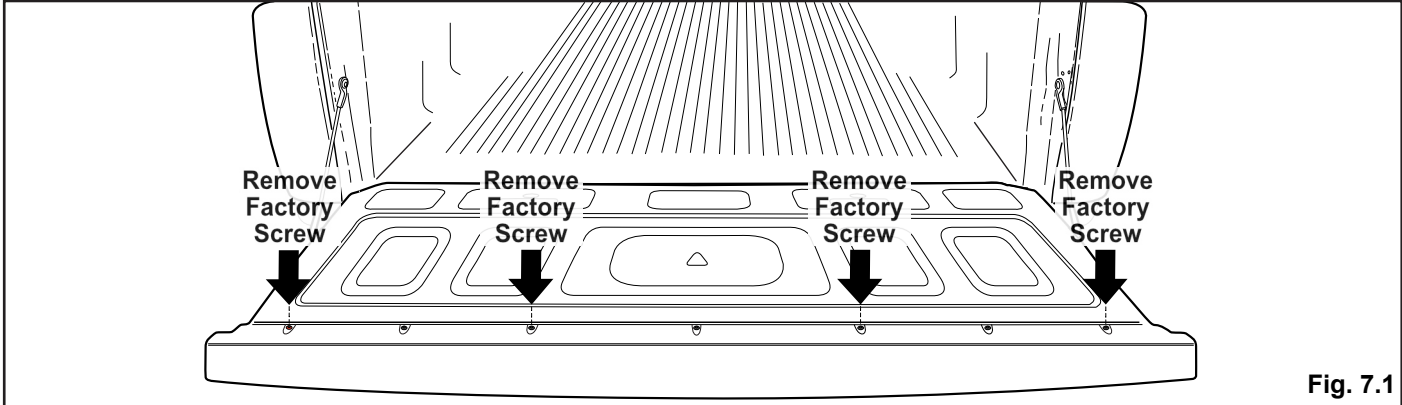

Fig. 7.1

- Remove the 4 factory screws as shown above from edge of the tailgate's plastic molding trim. Leave the other 3 factory screws in place.

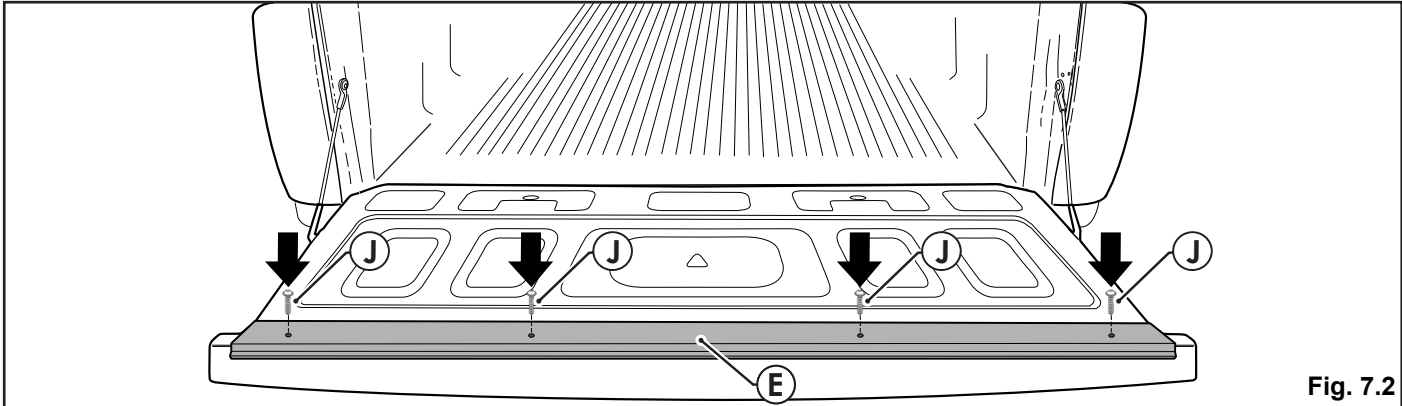

Fig. 7.2

- Place Tailgate Rail (E) in place, aligning it to the 4 screw holes that were removed in Fig. 7.1 and use 4 M6 screws (J) to attach the Tailgate Rail in place.

8 FIT THE TONNEAU COVER

- Attach the plastic J Retainer on front of the Tonneau Cover (A) to front lip of Front Rail (G) on Ute tub located behind the cab window. Fig 8.1 shows the cross section view.
- Engage back of the cover first with the Tailgate Rail, followed by the two sides of the cover to the Side Rails.

Note: Ensure the support bars are fitted underneath the Tonneau Cover to prevent water ingress and to keep the cover tight.

Use the pull tabs to assist whenever you open or close your cover.

Note: Fitment may be tight straight out of the box, but this should loosen up a little after a week or so.

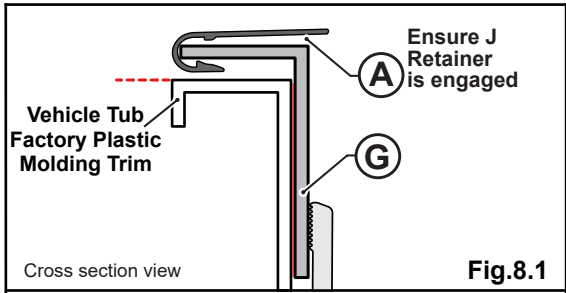

Fig. 8.1

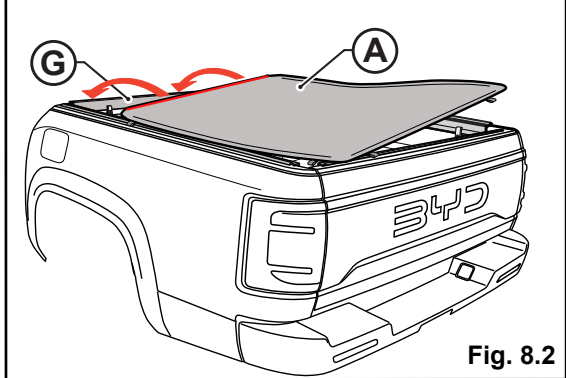
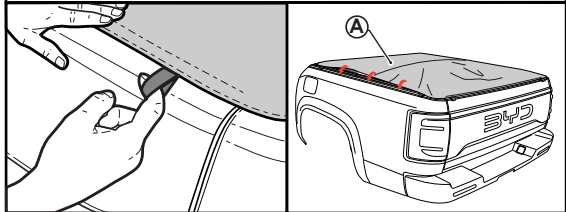



Fig. 8.2



ADJUSTING THE TENSION OF THE COVER

- To adjust the tension of the cover, you must adjust the height of the support bar. To do this, we have designed a patented adjustable bracket system which will allow you to freely adjust the height to any position within the range of the bracket.
- Simply loosen the bolt which goes through the Bar Bracket © and Clamp, then move the bracket either up or down until the bolt is at your desired level. Re-tighten the bolt.
- Your Adjustable Bar Bracket has a large tension range.
 - “L” lowers the height and loosens the cover.
 - “H” increases the height and tightens the cover.

	<p>“L” set here if cover is tight and hard to clip on.</p> <p>“H” set here if cover is loose or if water is pooling on it.</p>
---	--

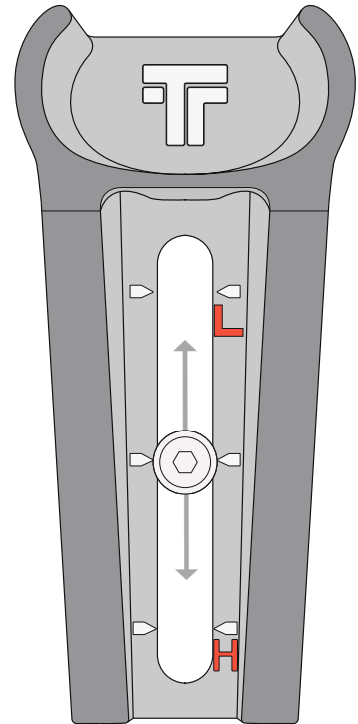

TONNEAU COVER TETHERING SYSTEM

STEP 1

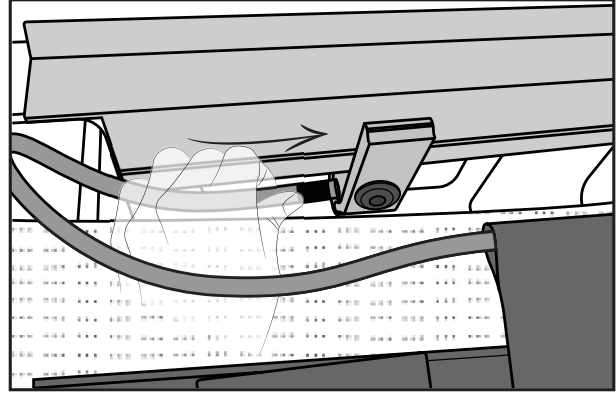
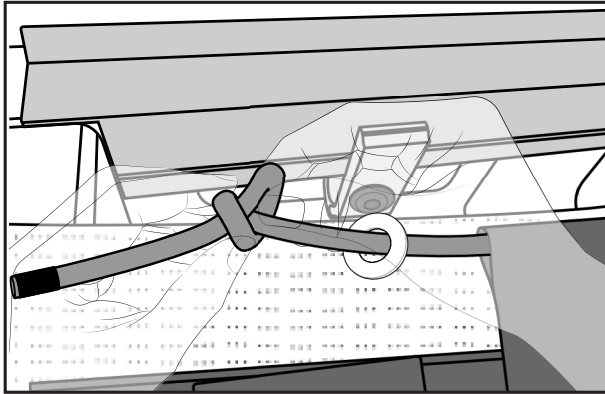

- Unclip the drivers side section of the cover from the aluminium rail.
- Untie the knot and remove the washer.
- Thread the rope through the clamp located near the front of the tub.

STEP 2

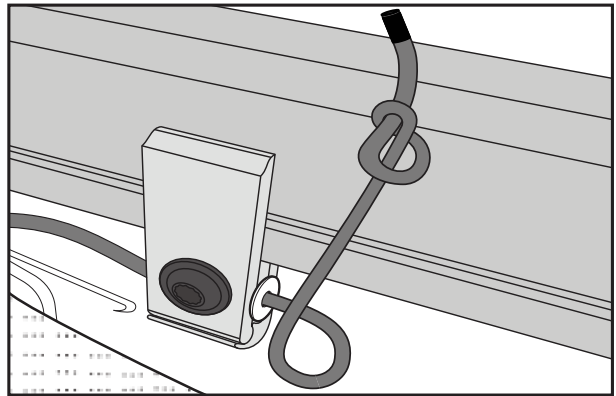
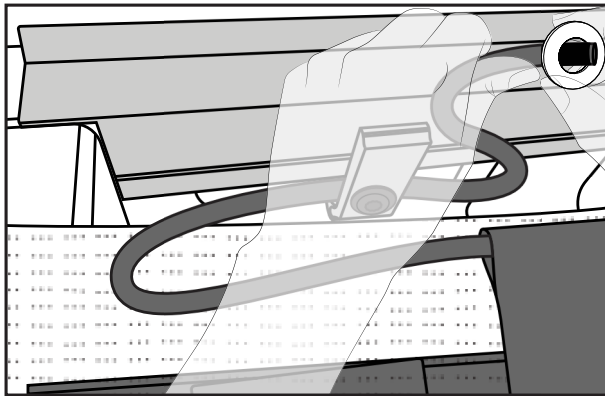

- Rethread the washer and tie the end of the rope in a knot.

STEP 3

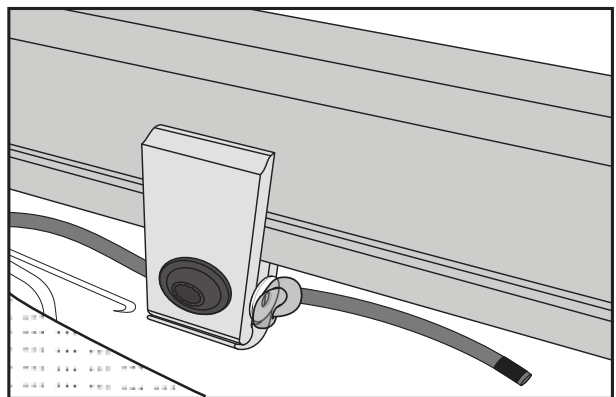
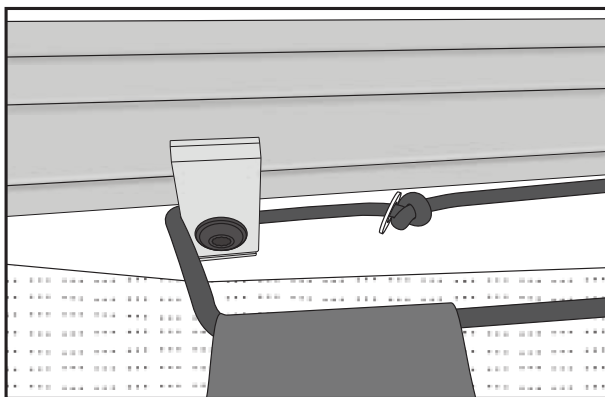

- With the washer in place the rope can not slip past the clamp.
- Repeat these steps for the passenger side.



Important

This product must be installed exactly as specified in this installation manual. Failure to do so may result in improper fit which can cause structural damage to the product and vehicle as well as serious accidents due to partial or complete loss of the product and void of warranty.

HOW TO USE THE OVERSIZED LOAD SYSTEM

STEP 1

- Place the load into the ute tub then drape the Tonneau Cover over it as shown.

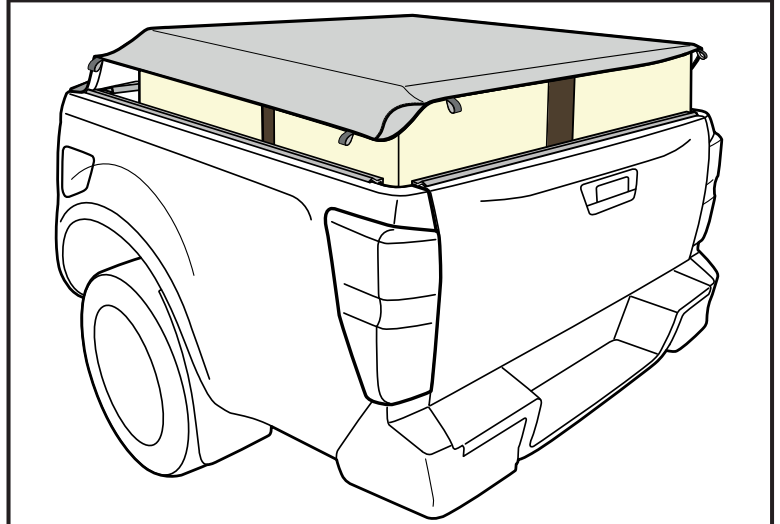

STEP 2

- Engage the Rope Hooks from underneath the Tonneau Cover and clip each one onto the Aluminium Rails.

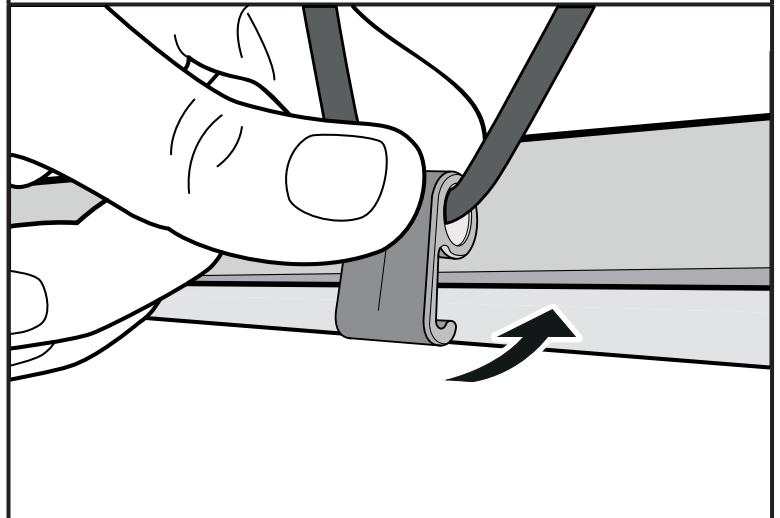

STEP 3

- Engage all Rope Hooks with even gaps to the side and rear Aluminium Rails for a secure fit.

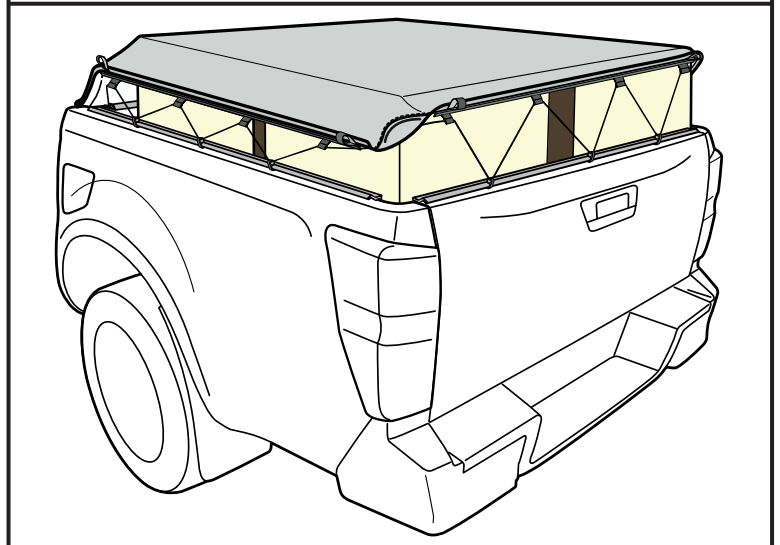

Important



The Tonneau Cover is not designed to be a load restraint. You **MUST** securely tie down your load first and then use the Oversized Load Cover System.