



LDV T60 MAX MEGA TUB

INSTALL INSTRUCTIONS

Part Number: 11767

- PARTS SUPPLIED

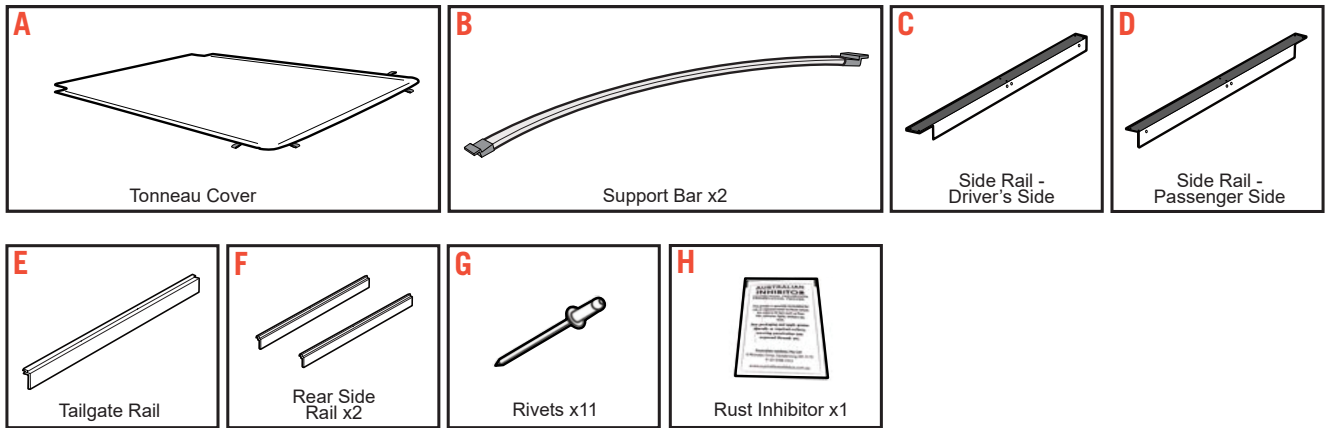

- SAFETY NOTES

- Ensure that appropriate Personal Protective Equipment is used.
- During the accessory fitment, ensure all Australian automotive and dealership safety practices are followed.
- Always refer to vehicle's workshop manual when removing components.



- FINAL ASSEMBLY

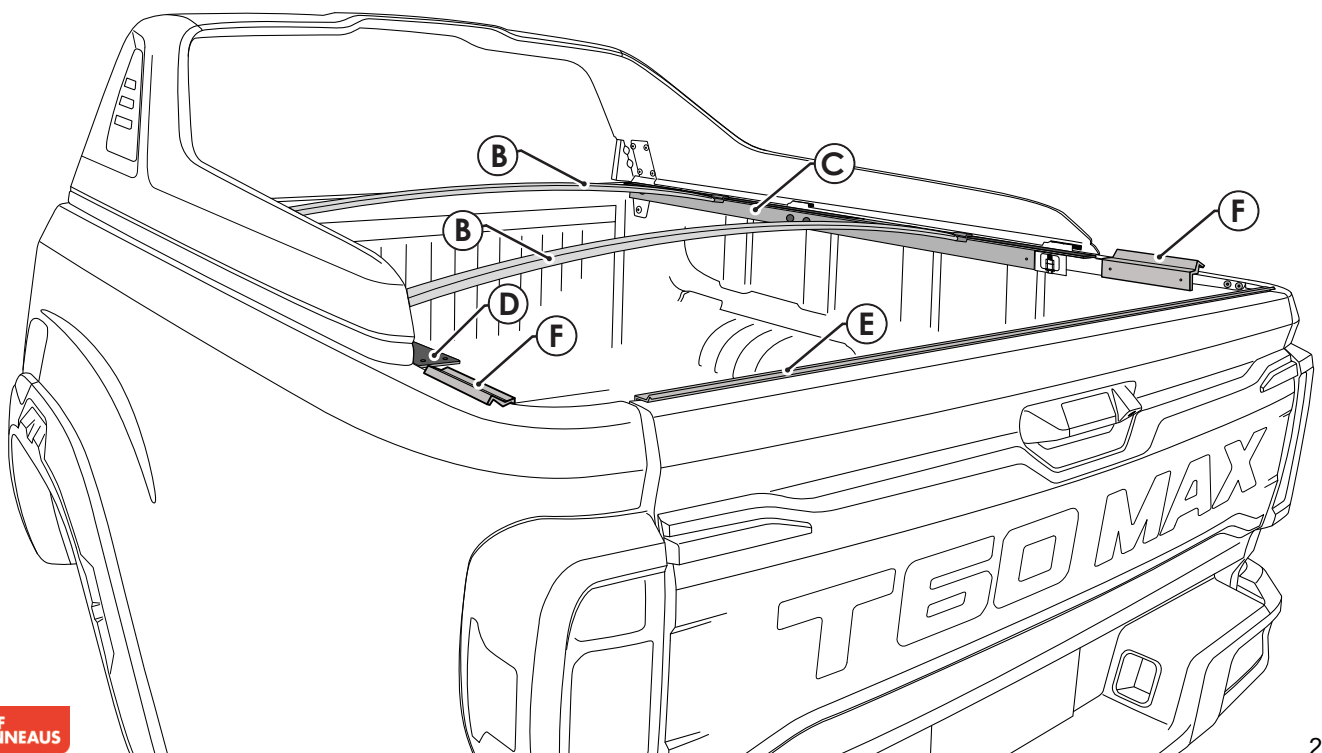

1

ATTACH SIDE RAILS

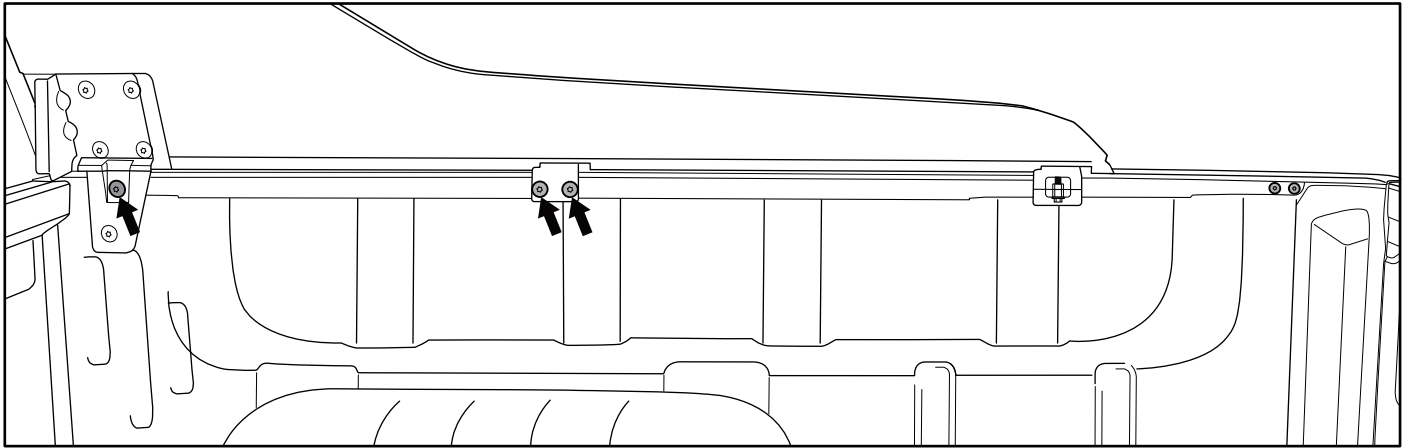

- Remove the three factory screws pointed above with T45 torx bit.

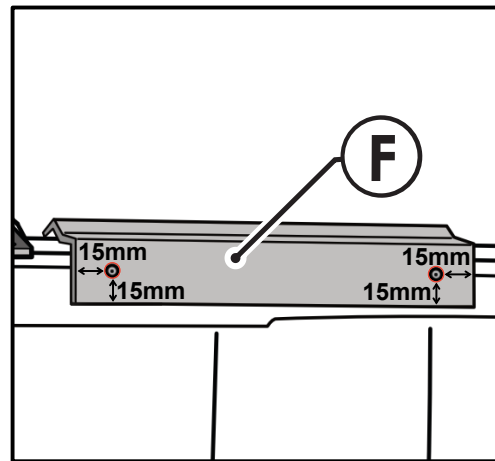
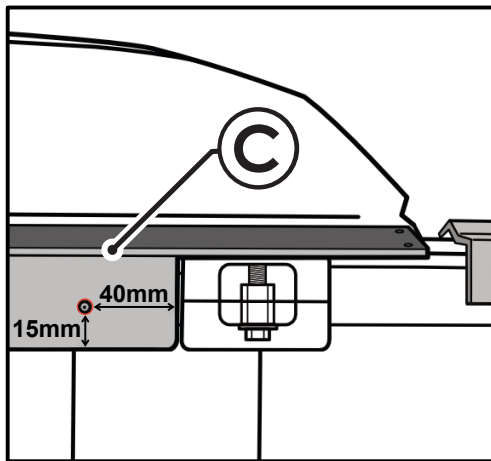

- Use above dimension guidance to drill holes with a 4mm drill bit

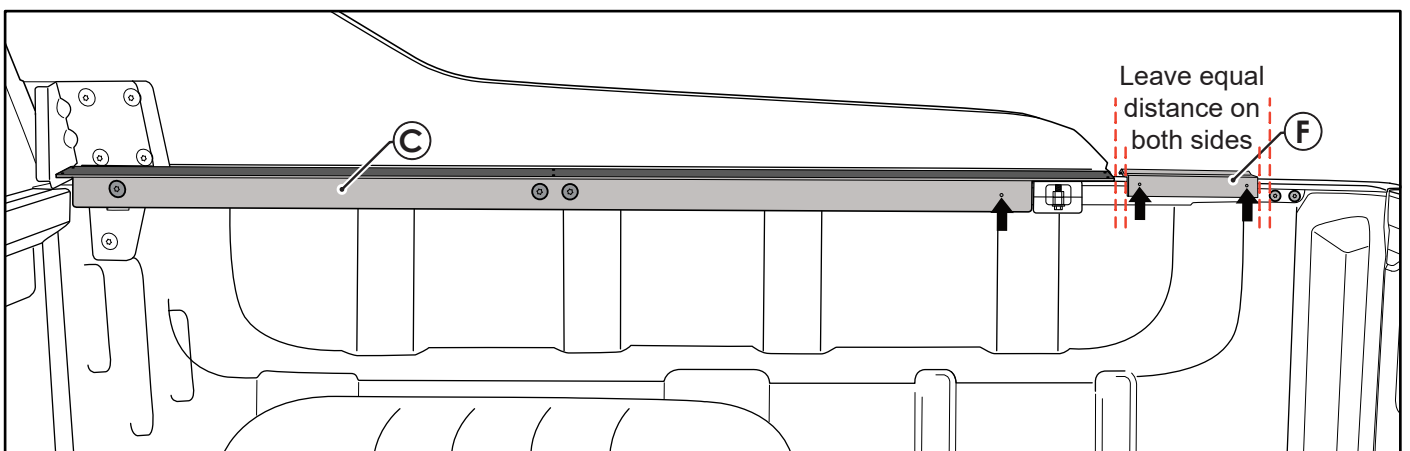

- Attach side rail **C** using the same factory screws with T45 torx bit. Drill 3 holes as shown above, following the dimensions given. Apply rust inhibitor **H** and then rivet into place the 3 rivets **G** with a rivet gun.
- Repeat for other side with side rail **D** and the second rear side rail **F**.

2 FIT THE SUPPORT BARS

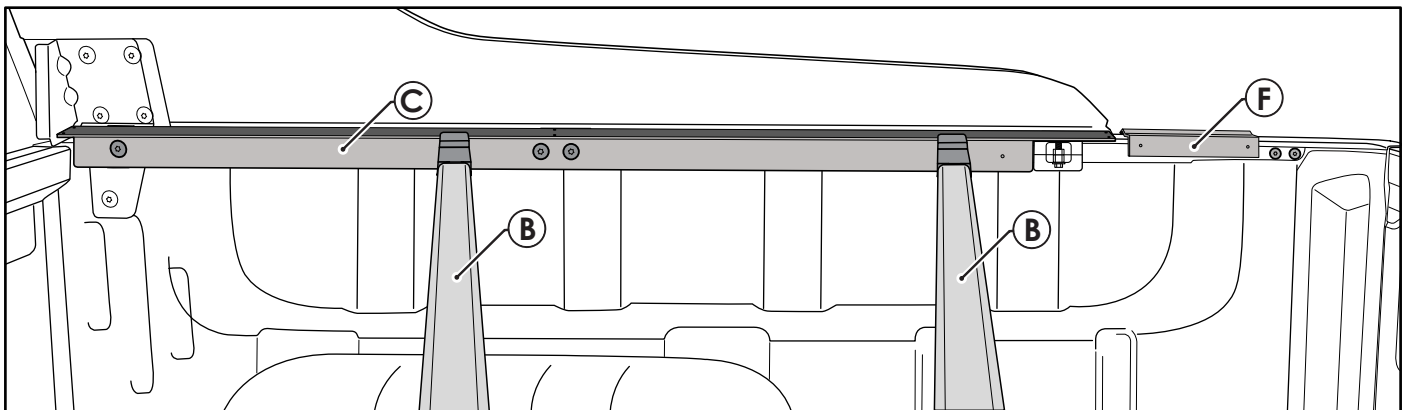
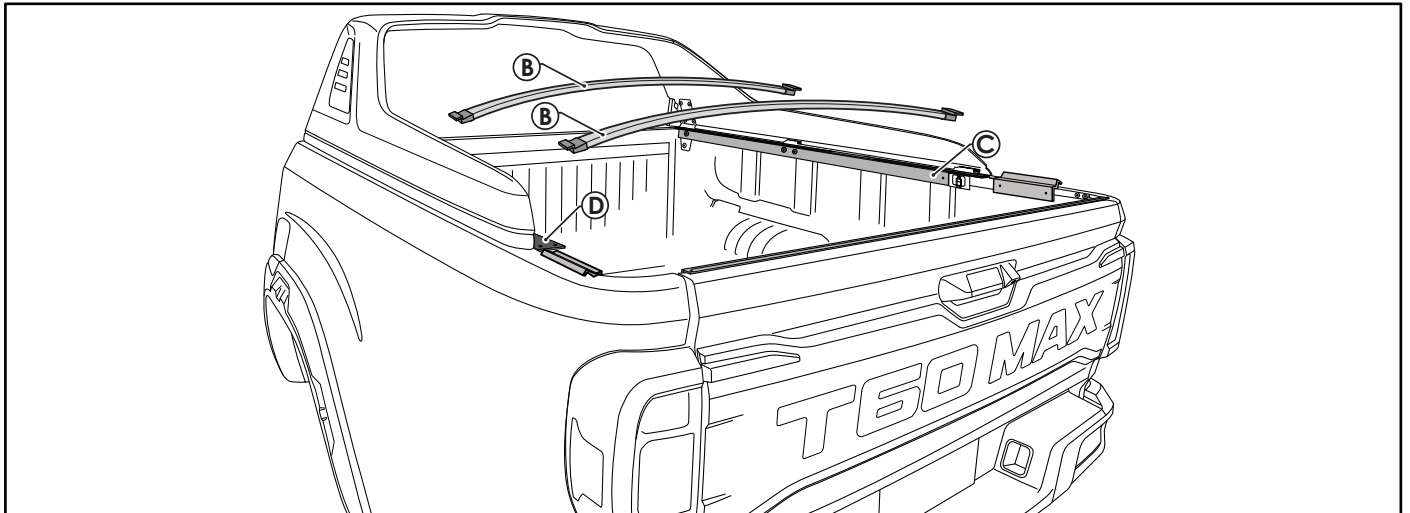

- Place the two Support Bars (B) with even distance from the middle of tub as shown above. Velcro on both ends of the Support Bars makes it easy to adjust the distance between them along the velcro surface on the Side Rail (C). Adjust them as required.
- Make sure the two support bars are seated in place with good velcro contact by pushing lightly on the centre of the two Support Bars (B).

3 DRILL THE TAILGATE RAIL

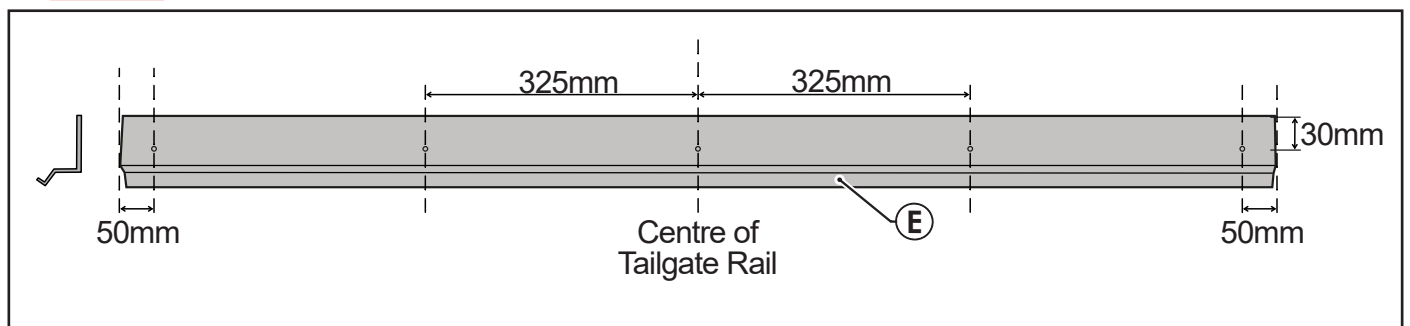

- Mark and drill the Tailgate Rail (E), 50mm in from each edge, 30mm up from the top edge of the rail as shown using a 4mm drill bit.
- Mark and drill the centre drill hole of the Tailgate Rail (E), with the same 30mm up from the top edge of the rail as shown.
- Then mark and drill the last two drill holes measuring 325mm on both sides of the centre drill hole.

4 DRILL, RIVET AND FIT THE TAILGATE RAIL

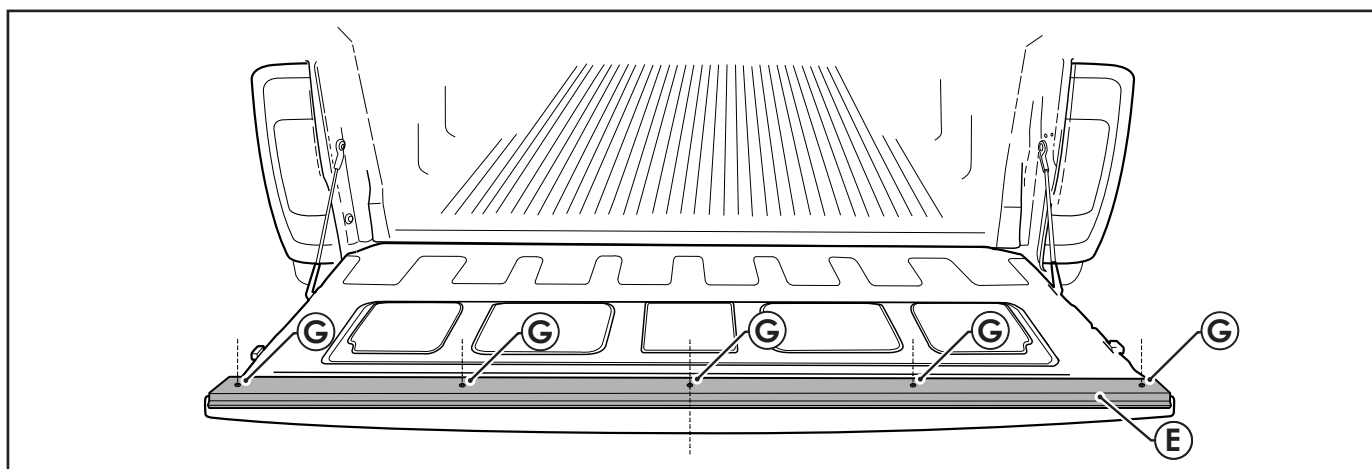

- Remove the red tape from back of the Tailgate Rail (E). Then stick the Tailgate Rail centrally onto the tailgate. Drill with a 4mm drill bit through the 5 holes. Apply rust inhibitor (H) and then rivet (G) the Tailgate Rail to the tailgate using a rivet gun.

5 FIT THE TONNEAU COVER

- Attach the plastic J Retainer on front of the Tonneau Cover (A) to front lip of the Ute tub located behind the cab window.
- Engage the back of the cover first, followed by the velcro on sides.

Note: Ensure the support bar is fitted underneath the Tonneau Cover to prevent water ingress and to keep the cover tight.



Use the pull tabs to assist whenever you open or close your cover.

Note: Fitment will be tight straight out of the box, but this should loosen up a little after a week or so.

