



Roll Up Tonneau Cover

FORD RANGER PY

INSTALL INSTRUCTIONS

Part Number: 11639

- PARTS SUPPLIED

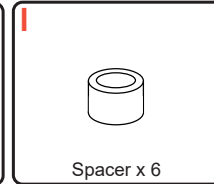
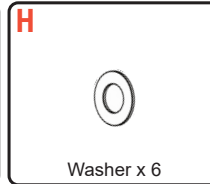
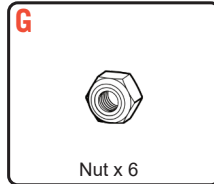
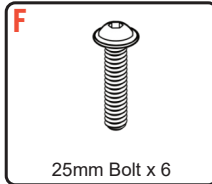
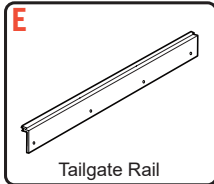
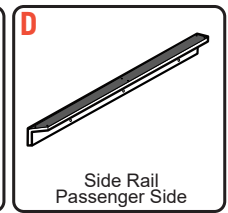
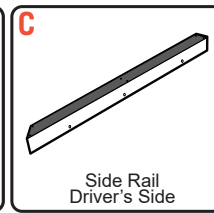
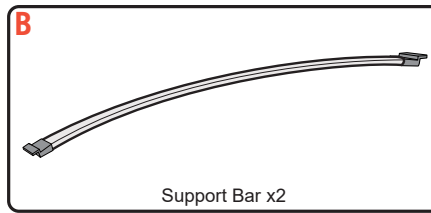
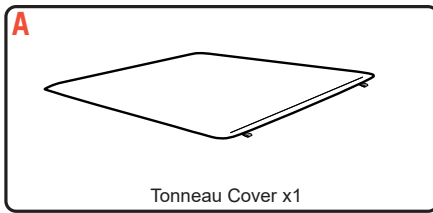

- TOOLS SUPPLIED

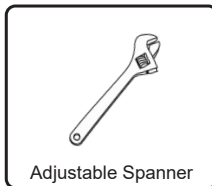
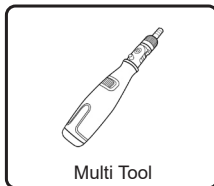

- SAFETY NOTES

- Ensure that appropriate Personal Protective Equipment is used.
- During the accessory fitment, ensure all Australian automotive and dealership safety practices are followed.
- Always refer to vehicle's workshop manual when removing components.



FINAL ASSEMBLY

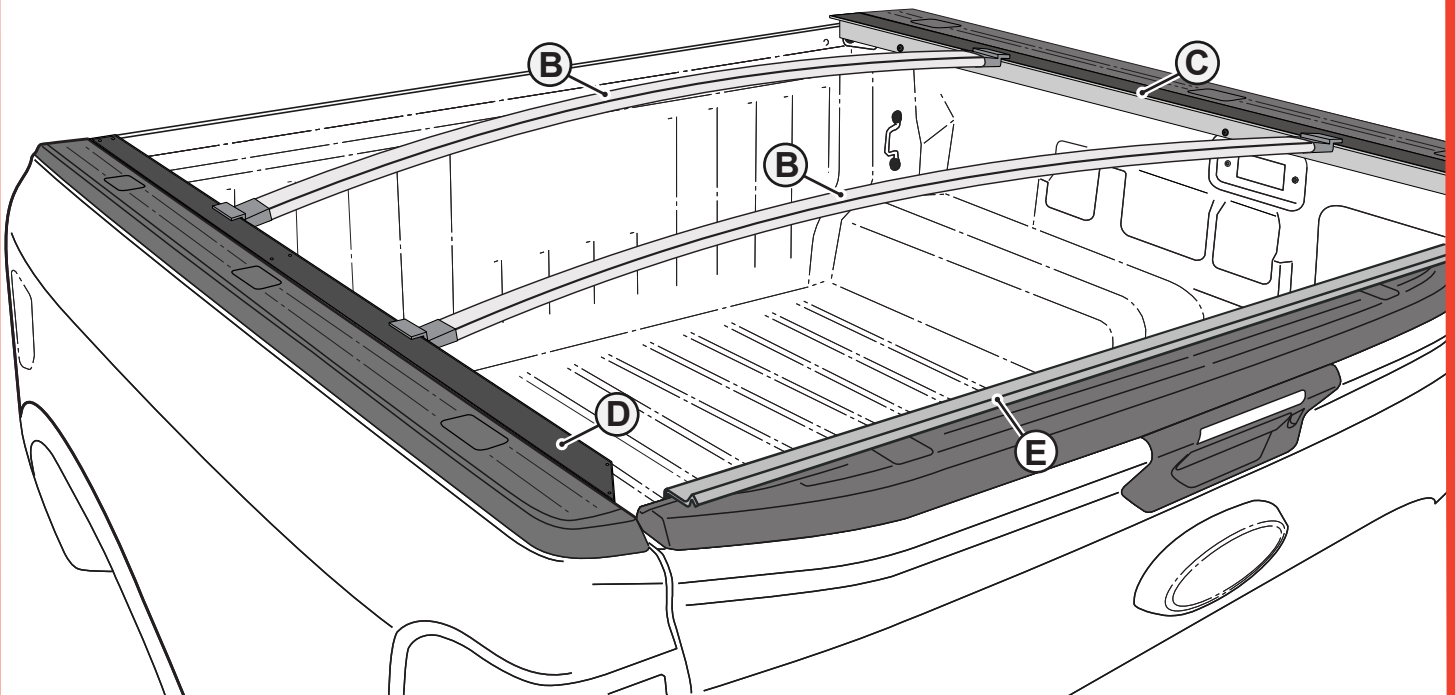

1 ATTACH SIDE RAILS

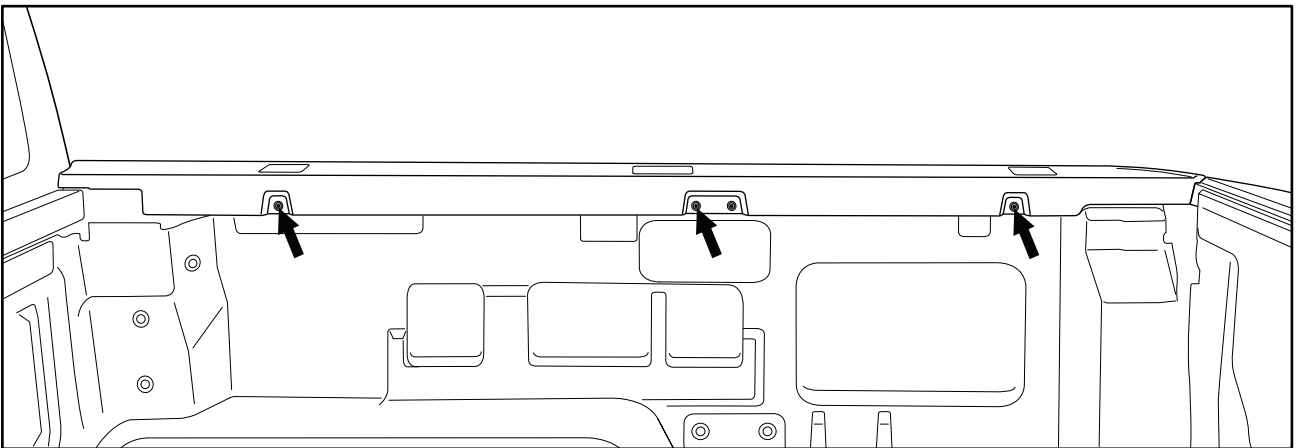

- Remove the three factory screws pointed above using a philips head in the multitool provided.

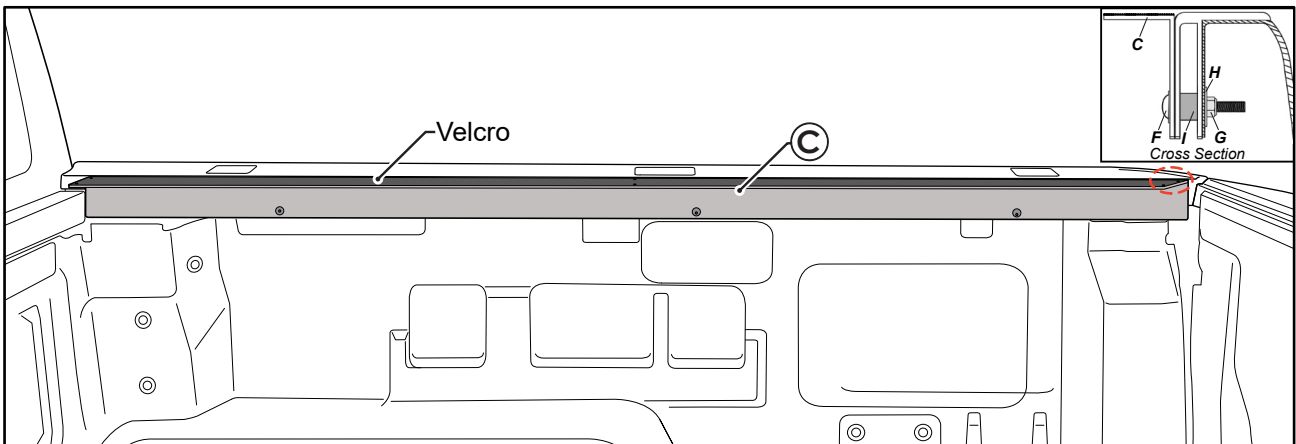

- Attach side rail (C) with the bolts (F), spacers (I), nuts (G) and washer (H) provided in the installation kit, using the multitool 4mm hex head and adjustable spanner. The spacers (I) fill the gap behind the rail.
- Repeat for other side with side rail (D).

2 FIT THE SUPPORT BARS

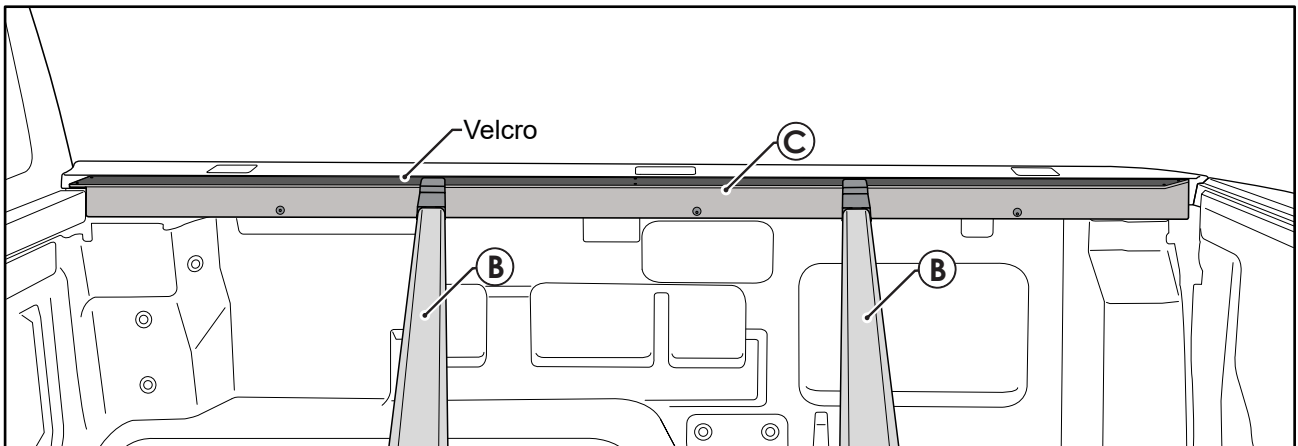
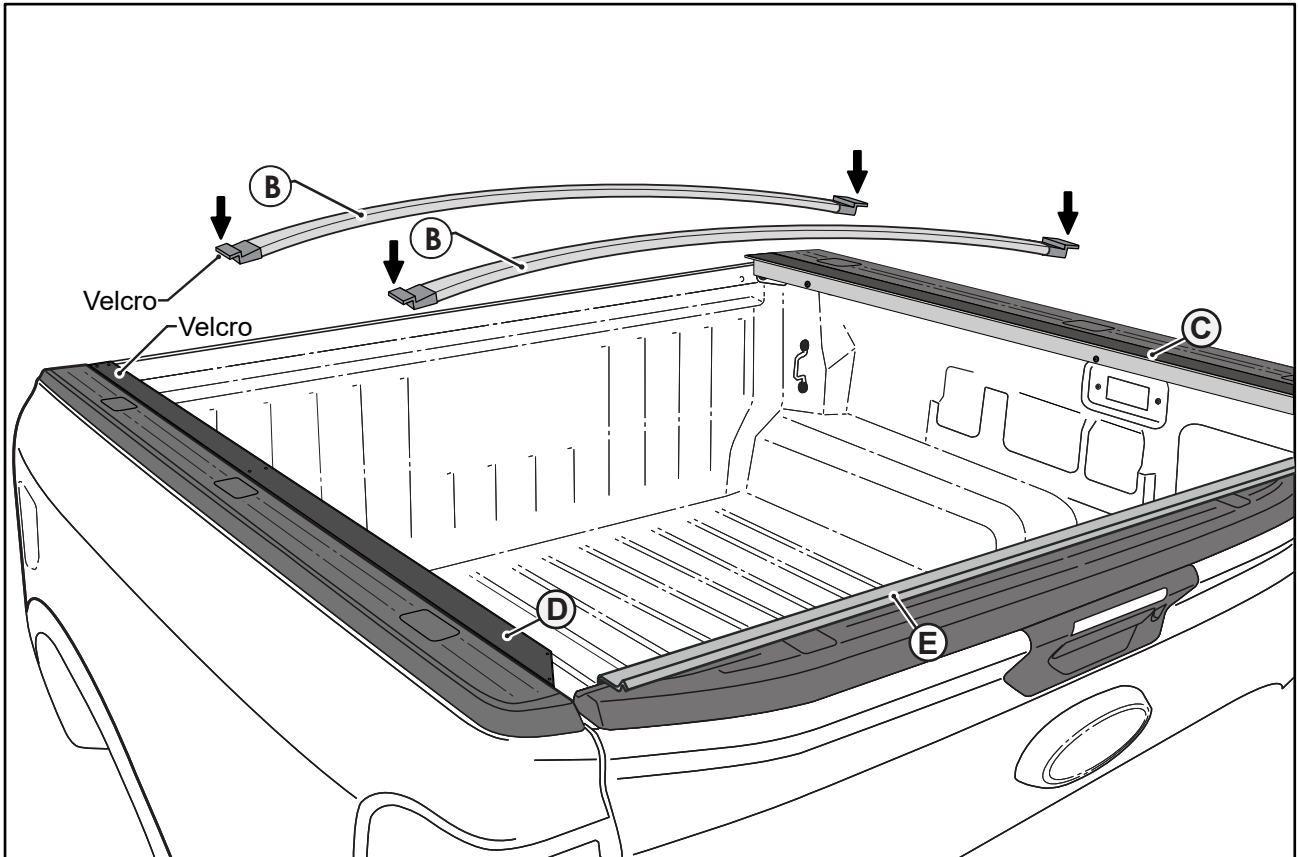

- Place the two Support Bars (B) with even distance from the middle of tub as shown above. Velcro on both ends of the Support Bars makes it easy to adjust the distance between them along the velcro surface on the Side Rail (C) and (D). Adjust them as required.
- Make sure the two support bars are seated in place with good velcro contact by pushing lightly on the centre of the two Support Bars (B).

3 PREPARE THE TAILGATE

For Vehicles with Tailgate Liners:

- If fitted with tailgate liner **①**, unscrew the 4 factory screws **②** as shown. The aluminium tailgate rail can go on top of the tailgate liner and the 4 factory screws can be used again to attach the tailgate rail.

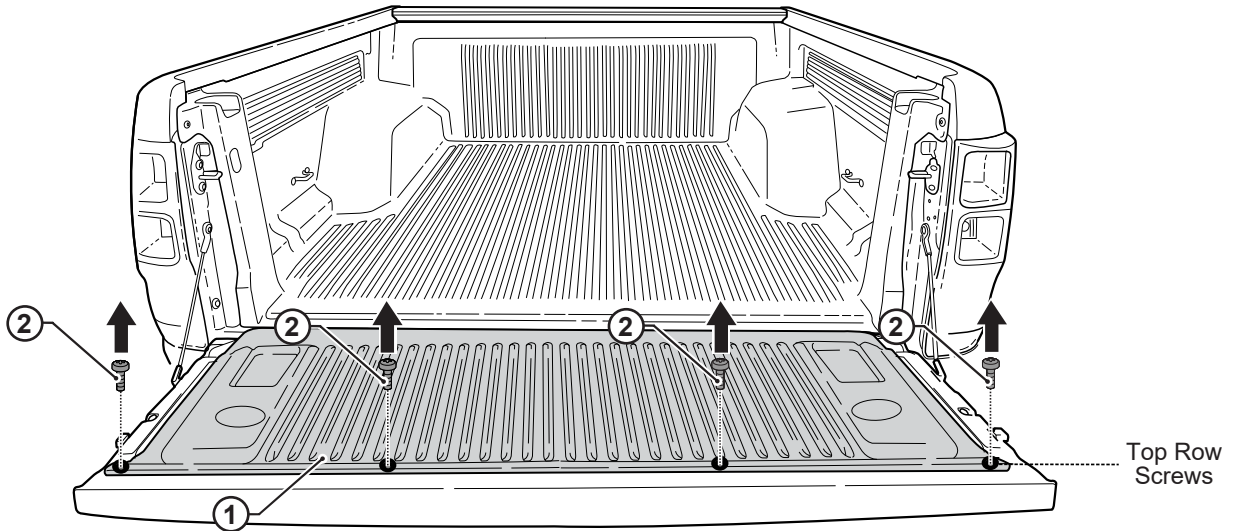

For Vehicles without Tailgate Liners:

- Unscrew the 4 factory screws **②** as shown. The aluminium tailgate rail can then be positioned in place and the 4 factory screws can be used again to attach the tailgate rail.

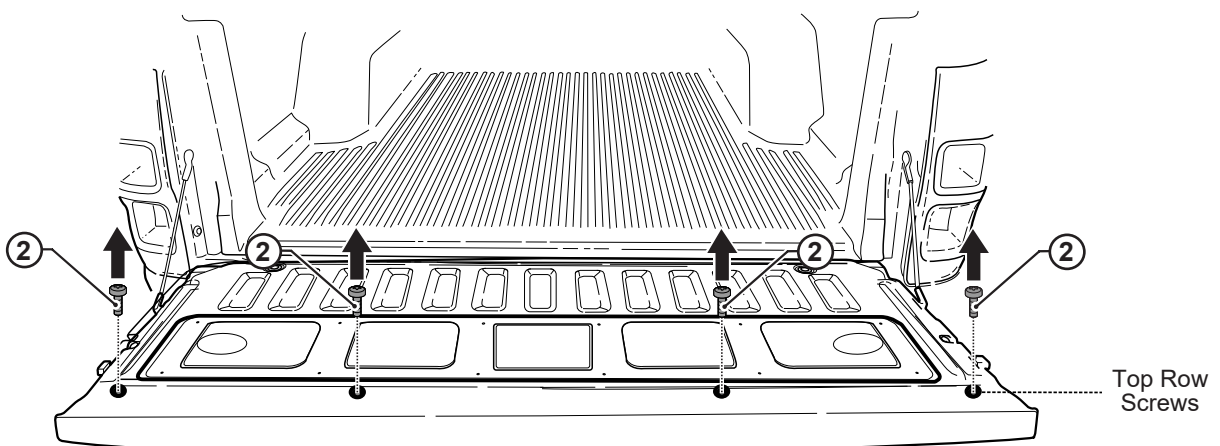
**Important**

Use **VERY** low torque when refitting factory screws as there is a risk the thread will strip.

4 ATTACH THE TAILGATE RAIL

- Fit the Tailgate Rail (E), on top of the tailgate or on top of the tailgate liner if it has one.
- Place the 4 factory screws (2) back on to secure the tailgate rail. Tighten using the Multi Tool provided.

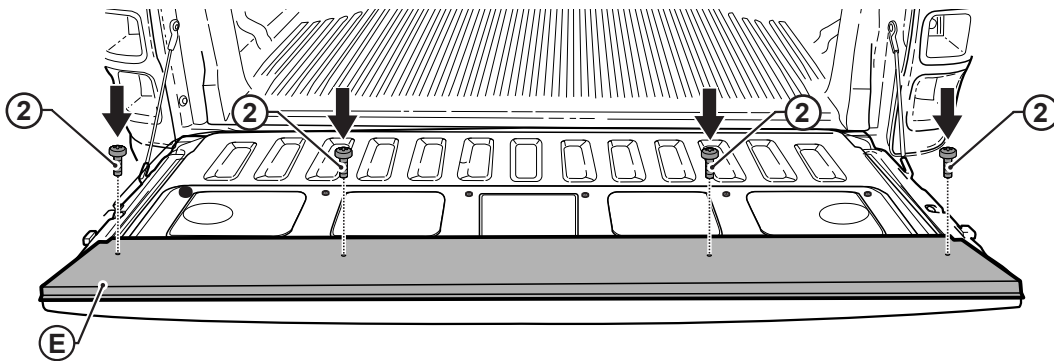
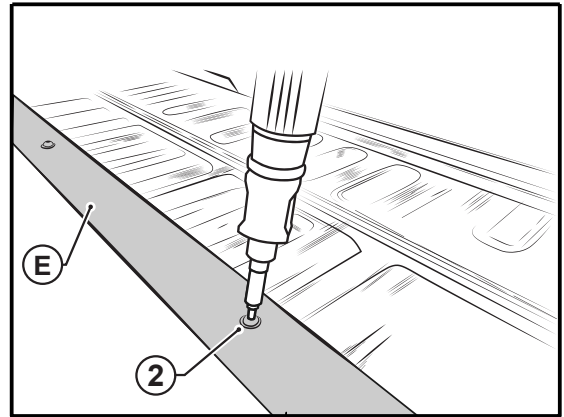

5 FIT THE TONNEAU COVER

- Attach plastic 'J Retainer' on the front of Tonneau Cover (A) to the front lip of the Ute tub located behind the cab window.
- Engage the back of Tonneau Cover first, followed by the velcro on the sides. Run your hands over the velcro sides, to engage the sides into place.

Note: Ensure the support bars (B) are fitted underneath the Tonneau Cover to prevent water ingress and to keep the cover tight.



Use the pull tabs to assist whenever you open or close your cover.

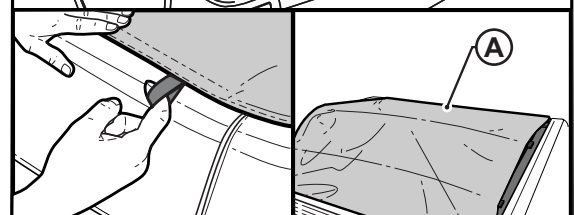
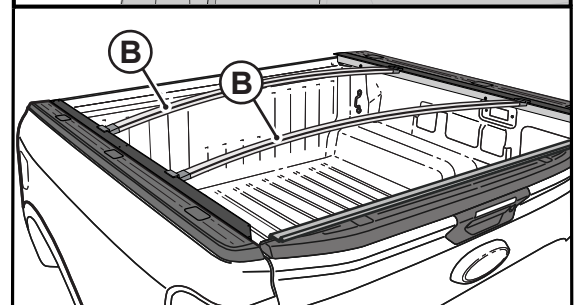
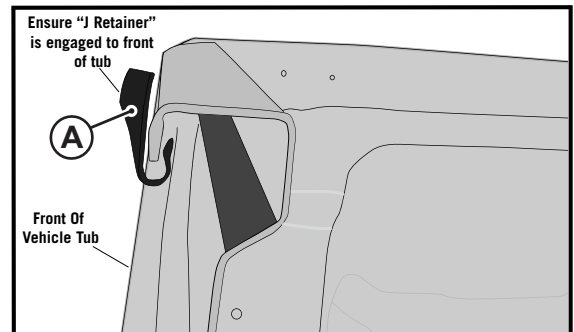

Note: Fitment will be tight straight out of the box, but this should loosen up a little after a week or so.

CONGRATULATIONS!
YOU HAVE SUCCESSFULLY INSTALLED YOUR
ROLL UP TONNEAU COVER.