

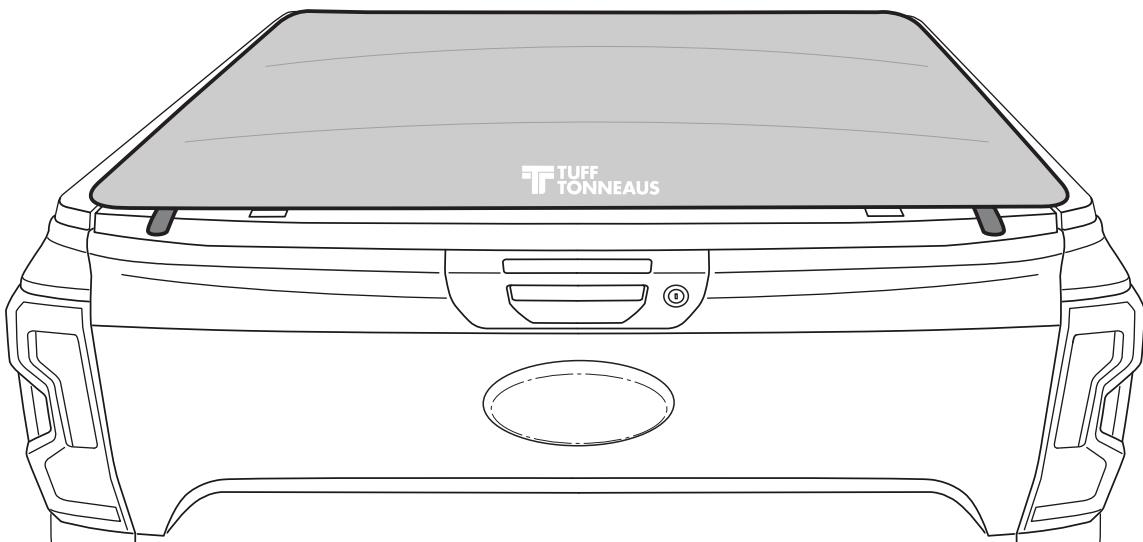

CLIPON 2.0[®]

INSTALL INSTRUCTIONS



FORD RANGER NON SPORTS BAR

- PARTS SUPPLIED

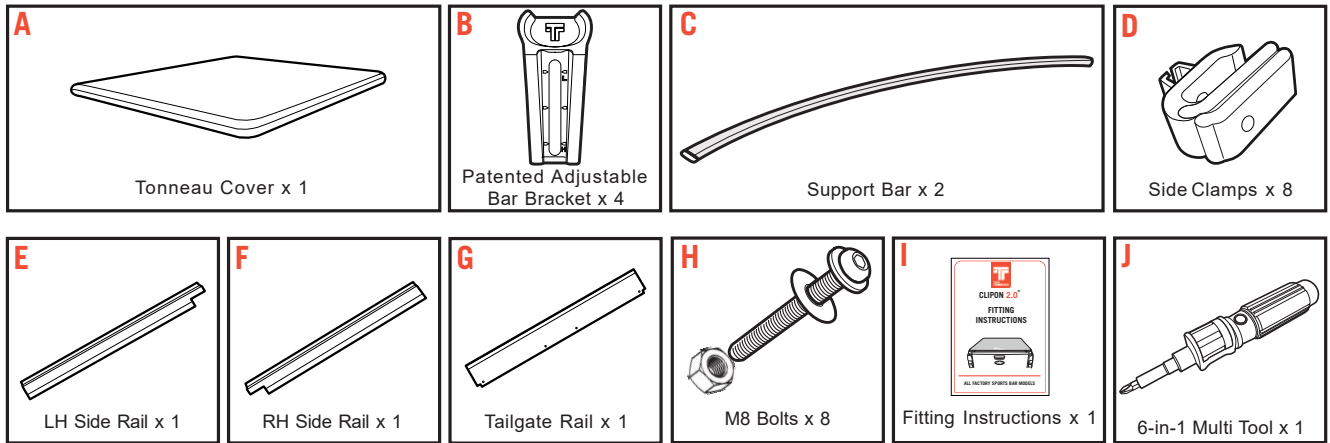

- SAFETY NOTES

- Ensure that appropriate Personal Protective Equipment is used.
- During the accessory fitment, ensure all Australian automotive and dealership safety practices are followed.
- Always refer to the vehicles workshop manual when removing components.



— FINAL ASSEMBLY —

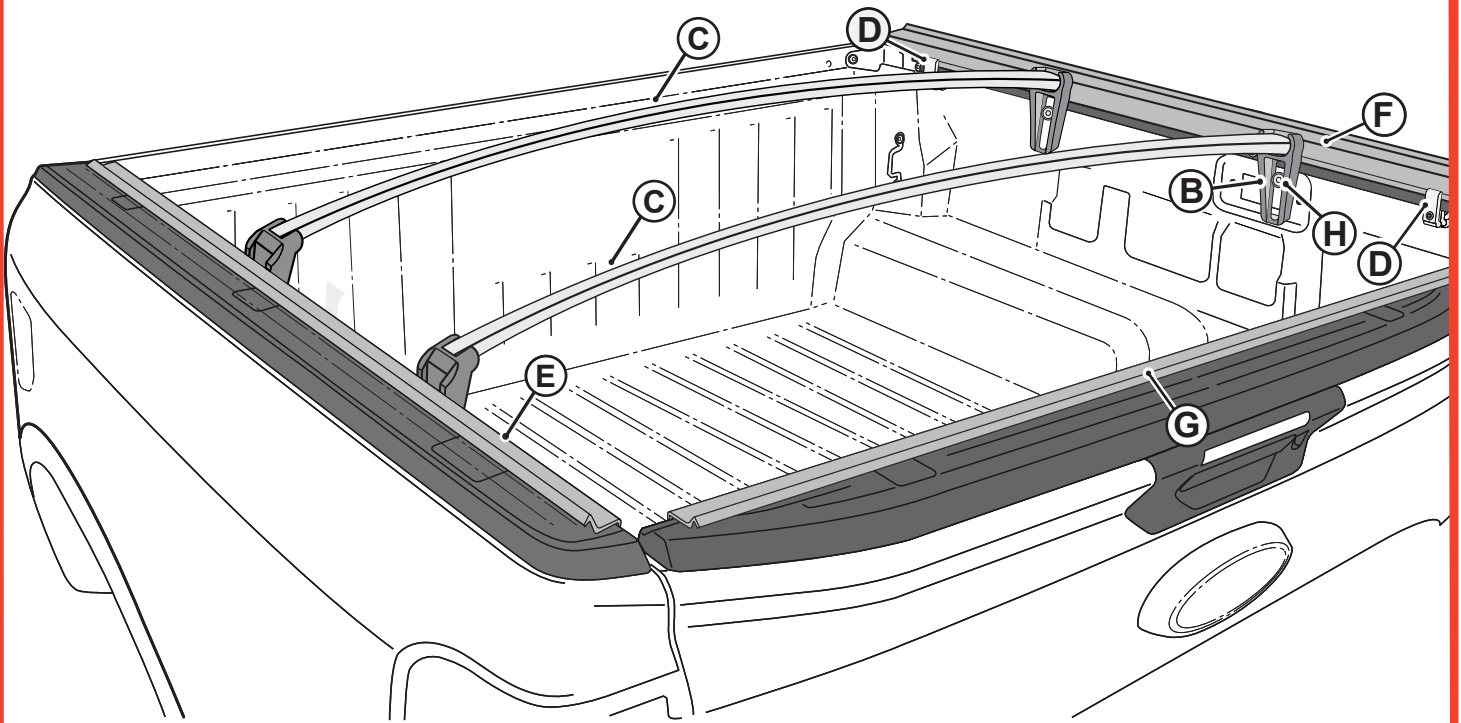

1

ASSEMBLING THE BAR BRACKET

STEP 1

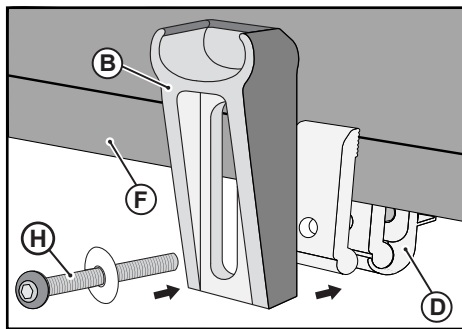

- Slide and attach the Patented Adjustable Bar Bracket (B) to aluminium on the Side Rail (F) as shown using M8 Bolt with washer (H) and Side Clamps (D).

STEP 2

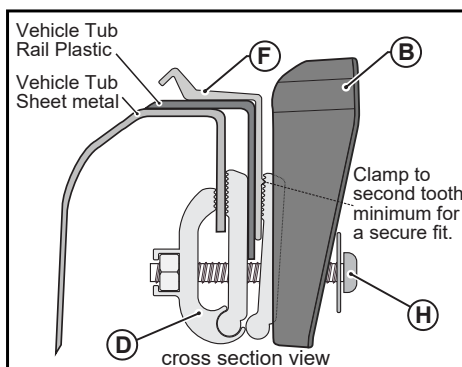

- Engage the Adjustable Bar Bracket (B) to Side Rails (F) as shown in order on the left. Repeat for opposite side.

2

ATTACH THE SIDE RAILS

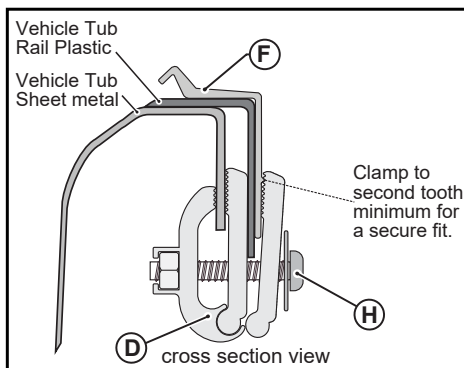
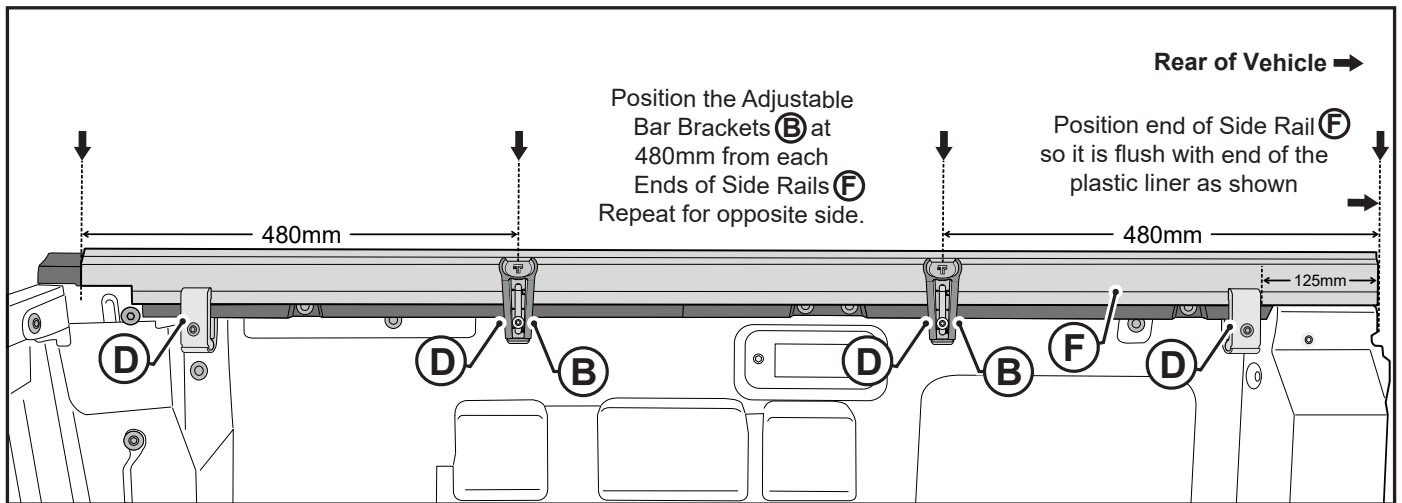

- Use 6-in-1 Multi Tool provided to tighten the M8 bolts.
- Repeat for the LHS.

3

FIT THE SUPPORT BARS

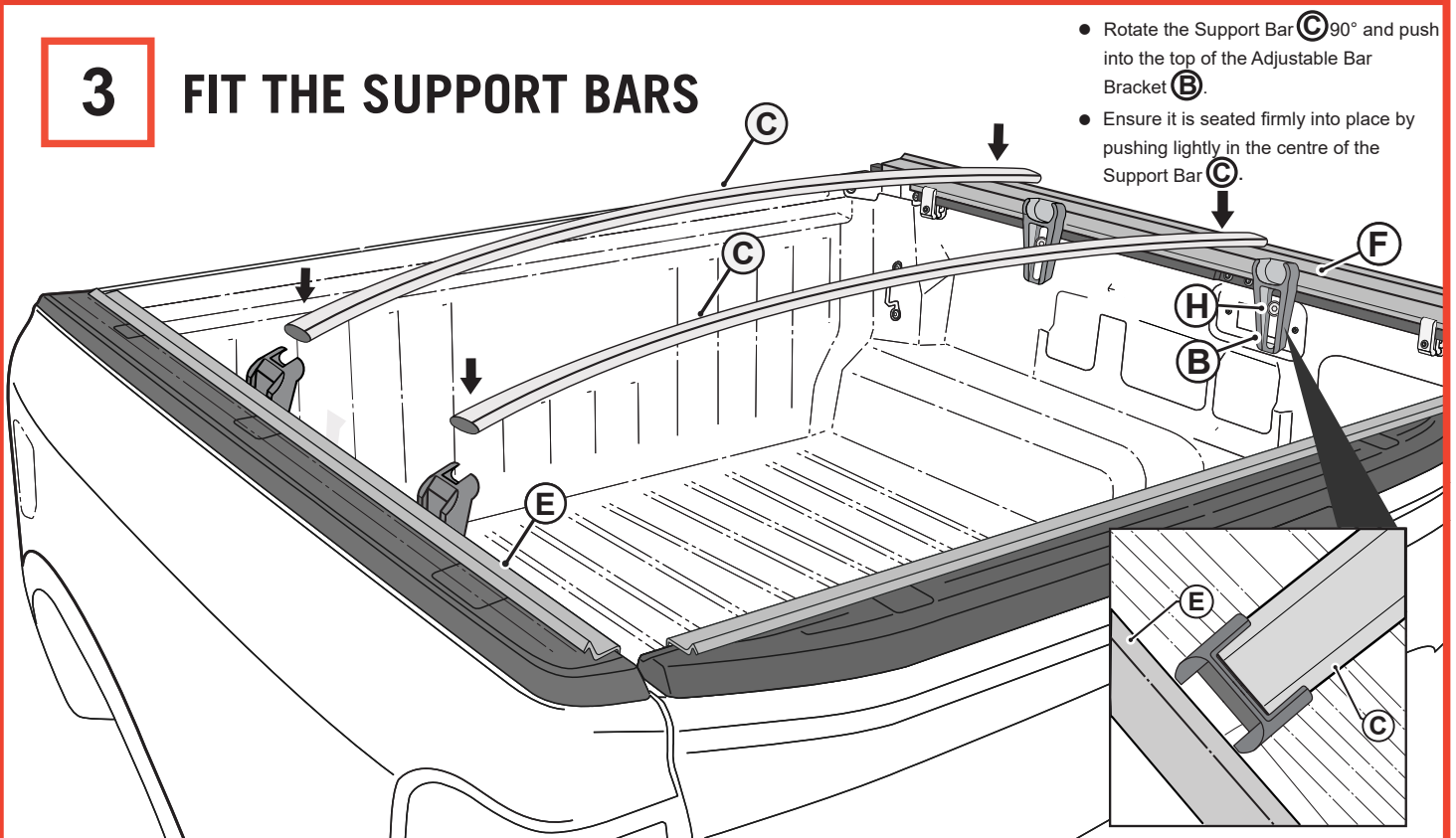

- Rotate the Support Bar (C) 90° and push into the top of the Adjustable Bar Bracket (B).
- Ensure it is seated firmly into place by pushing lightly in the centre of the Support Bar (C).

4

PREPARE THE TAILGATE

For Vehicles with Tailgate Liners:

- If fitted with tailgate liner ①, unscrew the 4 factory screws ② as shown. The aluminium tailgate rail can go on top of the tailgate liner and the 4 factory screws can be used again to attach the tailgate rail.

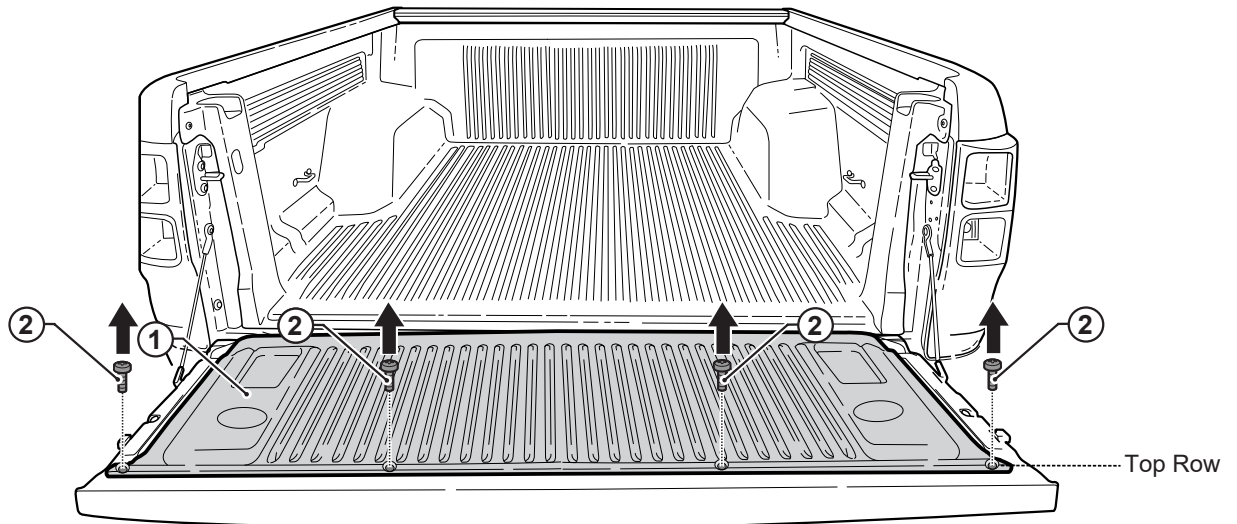

For Vehicles without Tailgate Liners:

- Unscrew the 4 factory screws ② as shown. The aluminium tailgate rail can then be positioned in place and the 4 factory screws can be used again to attach the tailgate rail.

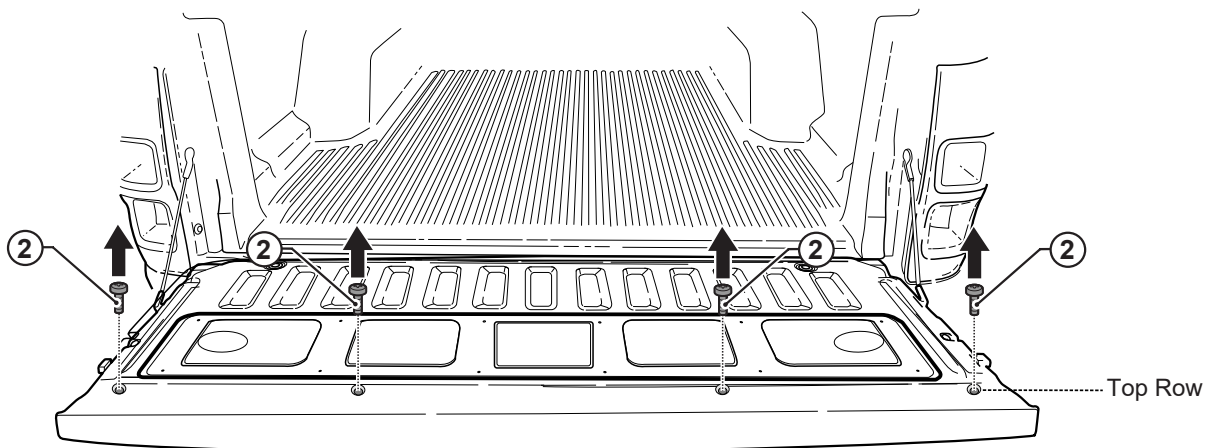

Important



Use VERY low torque when refitting factory screws as there is a risk the thread will strip.

5 ATTACH THE TAILGATE RAIL

- Fit the Tailgate Rail **G**, on top of the tailgate or on top of the tailgate liner if it has one.
- Place the 4 factory screws **2** back on to secure the tailgate rail. Tighten using the 6-in-1 Multi Tool **J** provided.

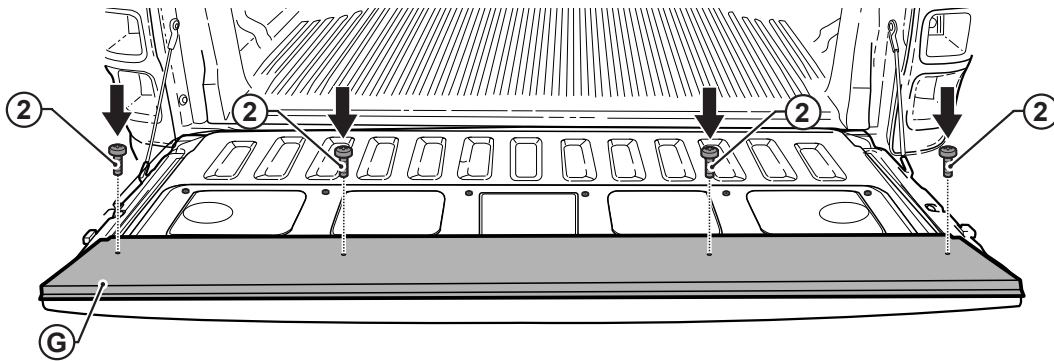
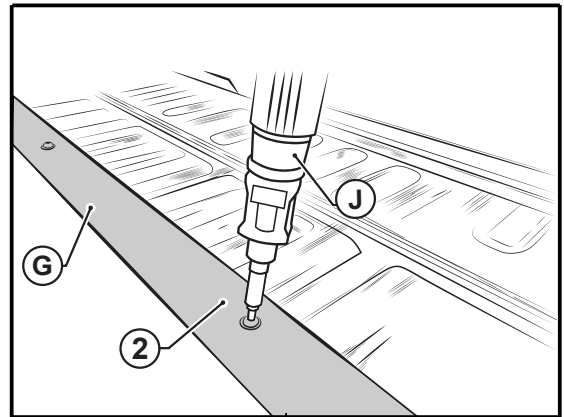

6 FIT THE TONNEAU COVER

- Attach the plastic 'J Retainer' on front of the Tonneau Cover **A** to the front lip of the Ute tub, located behind the cab window.
- Engage the back of Tonneau Cover first, followed by the sides.

Note: Ensure the support bars **C** are fitted underneath the Tonneau Cover to prevent water ingress and to keep the cover tight.



Use the pull tabs to assist whenever you open or close your cover.

Note: Fitment will be tight straight out of the box, but this should loosen up a little after a week or so.

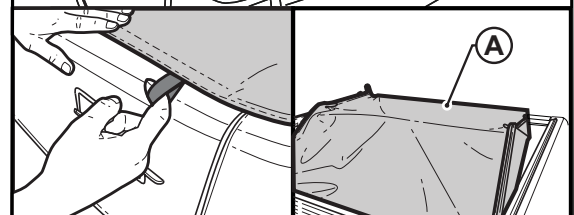
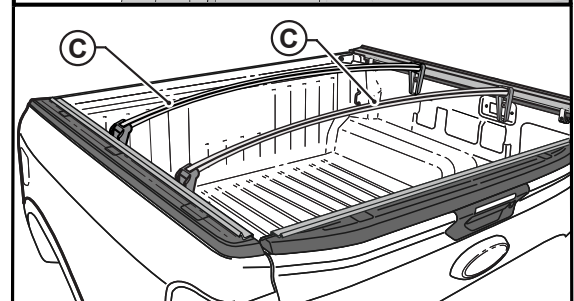
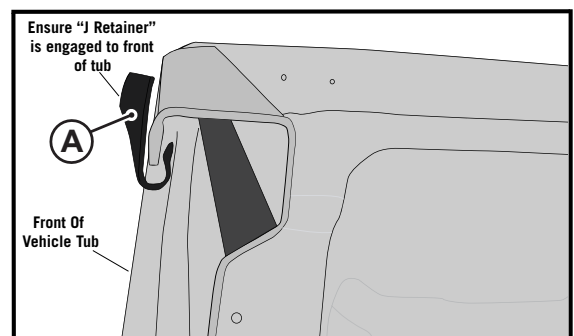

ADJUSTING THE TENSION OF THE COVER

- To adjust the tension of the cover, you must adjust the height of the support bar. To do this, we have designed a patented adjustable bracket system which will allow you to freely adjust the height to any position within the range of the bracket.
- Simply loosen the bolt which goes through the Bar Bracket **(B)** and then move the bracket either up or down until the bolt is at your desired level. Re-tighten the bolt.
- Your Adjustable Bar Bracket has a large tension range.
“L” lowers the height and loosens the cover.
“H” increases the height and tightens the cover.

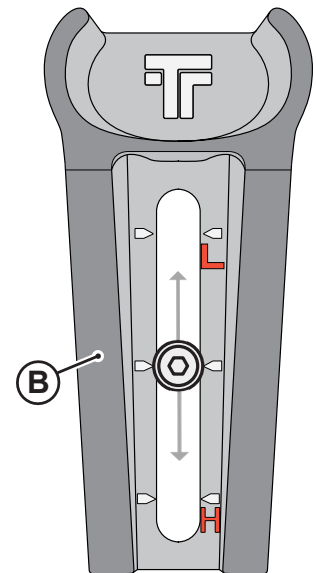

“L” set here if cover is tight and hard to clip on.

“H” set here if cover is loose or if water is pooling on it.

CONGRATULATIONS!
YOU HAVE SUCCESSFULLY INSTALLED YOUR
CLIPON 2.0[®] TONNEAU COVER