

TONNEAU FITTING INSTRUCTION

Isuzu D-Max Crew Cab with Over Rail Ute Liner

September 2020 - Current

Part number: 11341

Package includes

1 X Tonneau cover

2 x Bar Brackets

1 x Tonneau Support Bar

24 x Rivets

1 x Support Bar Sheath

16 x Rope Buttons

1 x Fitting Instructions

16 x Anti Abrasive Discs

1. TONNEAU COVER FITTING

NOTE Read entire instructions prior to start.

1.1 BASIC TOOL REQUIRED

Drill, 4mm Drill Bit, Rivet Gun, Marking Pencil / Pen

1.2 TONNEAU COVER INSTALLATION PROCEDURE

1. Fit The Bar Brackets and Support Bar

- Measure 740mm from the front inside edge of the tub. Place centre of Bar Bracket at this point with the top of Bar Bracket 10mm down from top edge of tub. Using the Bar Bracket as a guide, drill into the body.
- Apply rust inhibitor and rivet the front and rear holes to complete attachment of the Bar Bracket. Repeat for the passenger side of vehicle.
- Fit Support Bar according to Section 3 of this Instruction.

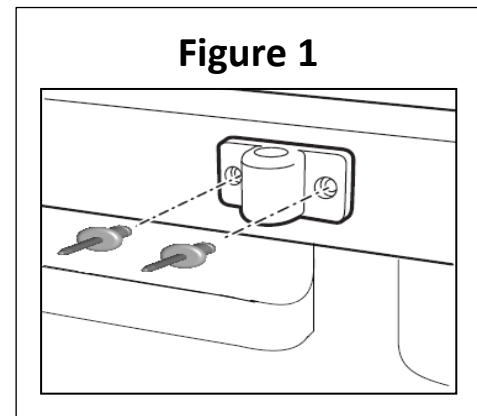

2. Fit The Buttons To The Tailgate

- Hook the front of the Cover onto the front edge of the Ute Tub. Centre the cover and evenly spread across the tub.
- To fit buttons, vertically line up each button to each bunji loop, **Starting from the Centre Bunjis**. The height of the 6 Tailgate Buttons are 460mm from the bottom edge of the tailgate.
- Drill holes then apply rust inhibitor and rivet buttons into place, attaching the bunji after each button is placed. **See Figure 2**

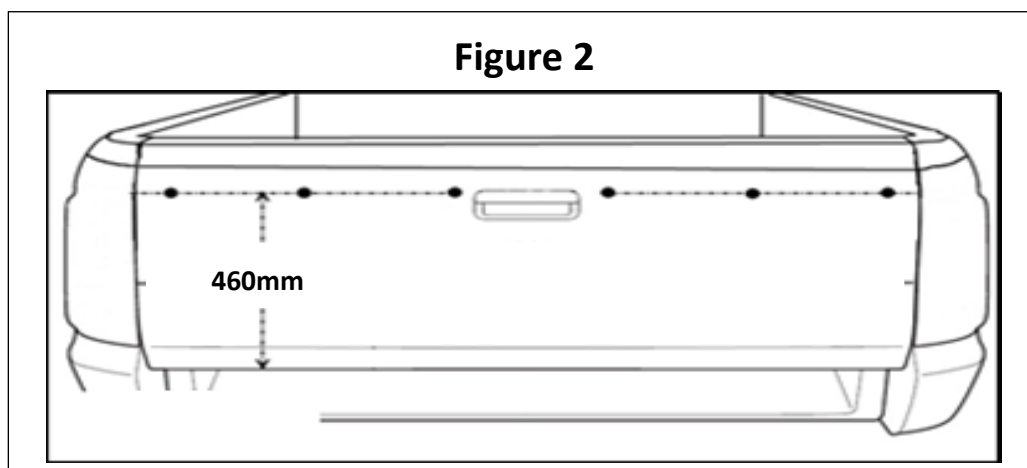

3. Fit The Buttons To Tub Sides

- (a) Measure down **185mm** from the inside edge of the tub, in line with the Front Bunji on the Cover, and mark. **This is the position of the front button.** See *Figure 3*

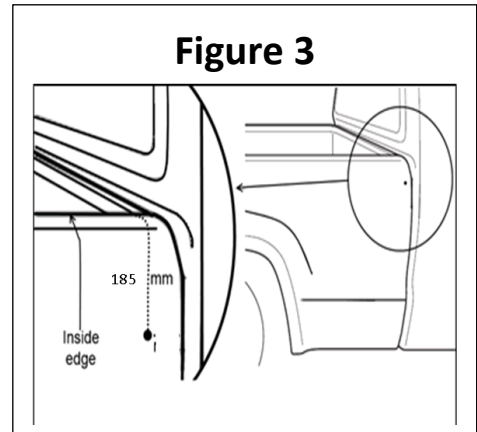

- (b) Measure down **155mm** from the inside edge of the tub, in line with the Rear-Side Bunji and mark. See *Figure 4*

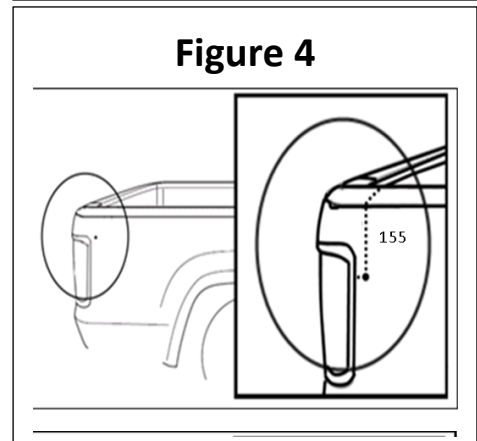

- (c) Using a straight edge or string line, draw a line between front mark & rear mark as shown in *Figure 5*

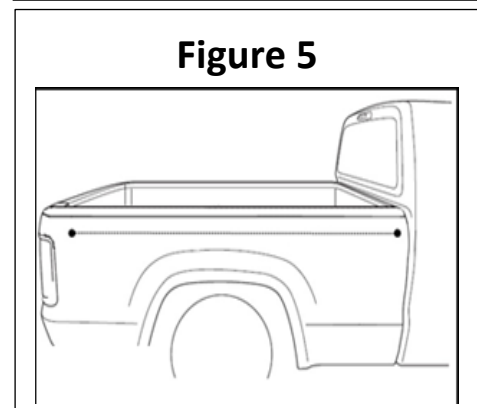

- (d) Repeat those steps for passenger side

NOTE: Figures are for illustration only, showing 6 Bunjis. Actual quantity may differ.

- (e) Work from the rearmost bunjis towards the front, alternating from side to side.
- (f) Line up the rearmost bunji loop (#1) on the driver's side of the vehicle and make a mark on the line drawn in step 4 (c).
- (g) Drill hole and rivet button into place as shown in **Figure 12**.
- (h) Repeat step 3 (e) to (g) for the rear most bunji loop (#2) on the passenger side of the vehicle.
- (i) Fit remaining 8 bunjis following the sequence as in **Figures 6 & 7**.

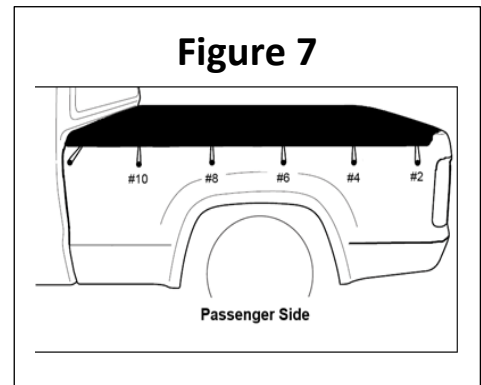
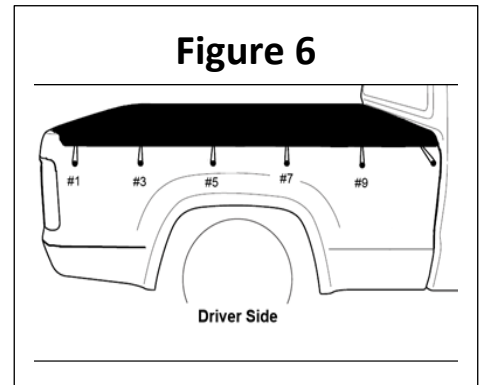

Note: Ensure you work from side to side to maintain tension across the tonneau cover

2. MULTI-FIT SUPPORT BAR

The Tuff Tonneau Multi - Fit Support Bar is designed to fit almost all Utes on the Market, from Subaru Brumbys to Cab Chassis aluminium trays.



3.1 BASIC TOOL REQUIRED

Drill, 4mm drill bit

3.2 MULTI-FIT SUPPORT BAR CONTENTS

- 1 x hollow bar centrepiece
- 2 x grub screws
- 2 x solid bar end piece
- 1 x Tonneau bar sheath

3.3 FITTING MULTI-FIT BAR

1. Insert solid bar pieces into either end of hollow tube. Adjust bar so it fits between bar bracket holders with the holes facing to the ground (so the grub screws don't rub against the tonneau), as shown above and then with a white pencil make a mark through the small holes of the hollow bar onto the solid ends. This is where you will drill a hole to the depth of about 1-2mm (do not go any further)
2. Join the pieces back together and screw grub screws through the hollow bar into the holes that you drilled. **Make sure you do not over tighten the grub screws.** Then place the tonneau sheath over the bar to stop the bar wearing against the tonneau. Refit the bar. You may kink the bar in the middle to give it some extra height to assist with water runoff.

Warning if you do not fit the tonneau sheath over the bar, the tonneau cover will quickly wear through which is not covered by warranty.

4. WARRANTY AND FEEDBACK

Please register your warranty details online at:

QR Code:



Website Link:

<http://www.tto.com.au/en-au/warranty.html>

**Please complete our 2 minute feedback section as we strive to constantly improve for
our customers.**