

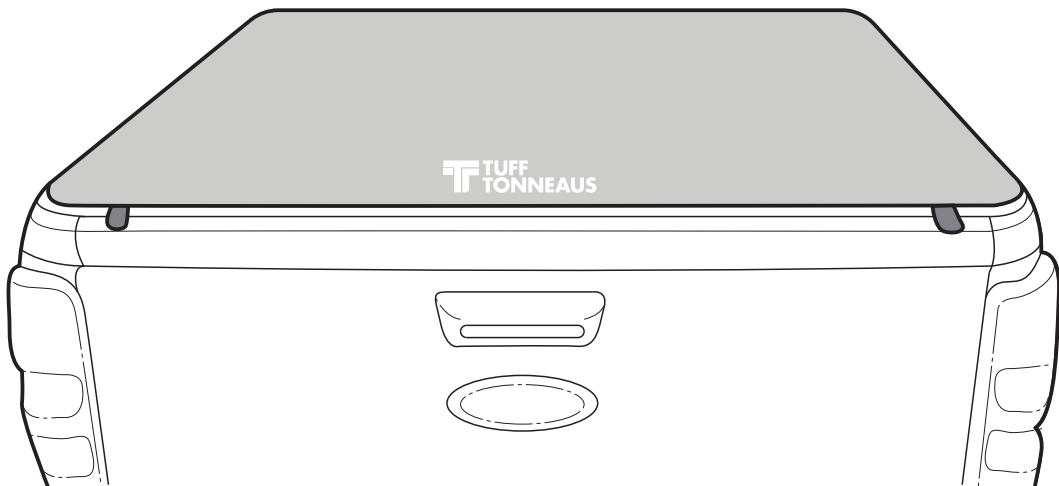

# CLIPON 2.0<sup>®</sup>

## INSTALL INSTRUCTIONS



---

**RAM 1500 / 2500 COVER  
TO SUIT 6'4" TUB**

## - PARTS SUPPLIED

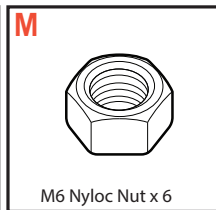
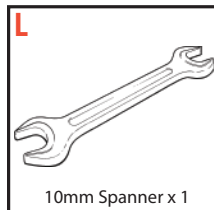
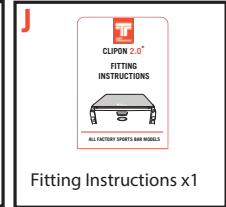
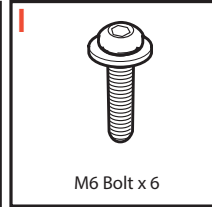
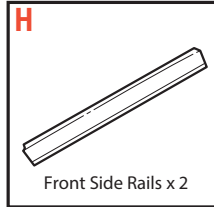
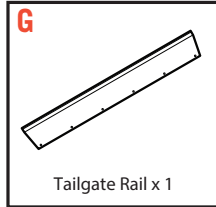
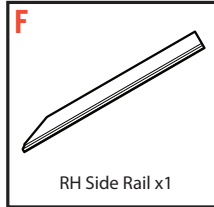
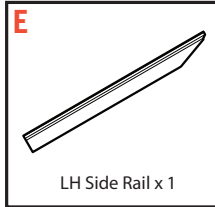
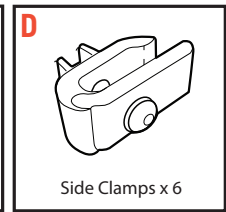
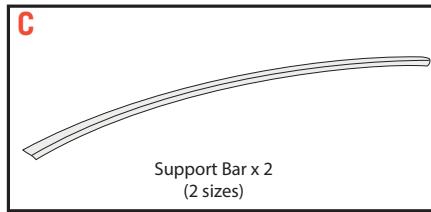
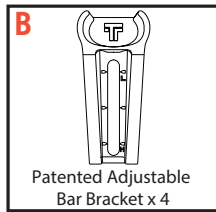
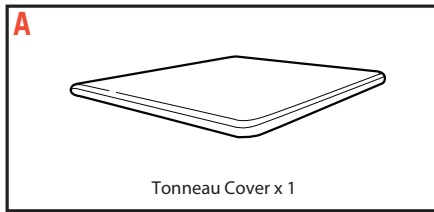

## - SAFETY NOTES

- Ensure that appropriate Personal Protective Equipment is used.
- During the accessory fitment, ensure all Australian automotive and dealership safety practices are followed.
- Always refer to the vehicles workshop manual when removing components.



## - EXAMPLE FITTING VIDEO

- Please also check out our video of fitting a 2.0 tonneau cover.
- Visit the following link: <http://bit.ly/nodrill-tonneau>
- Or simply scan the QR code.
- NB: Some models may vary slightly in fitment, so always consult your fitting instructions for more information.



## - FINAL ASSEMBLY -

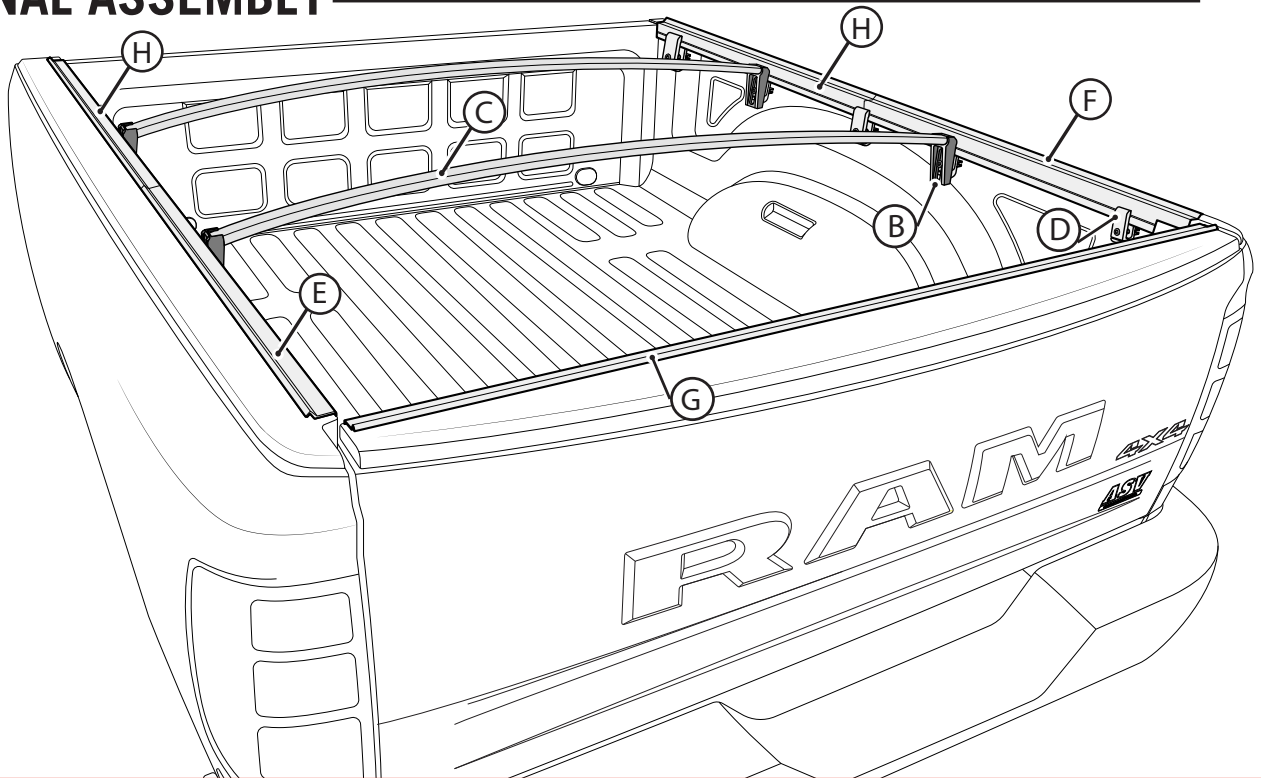

1

### ASSEMBLING THE BAR BRACKET

#### STEP 1

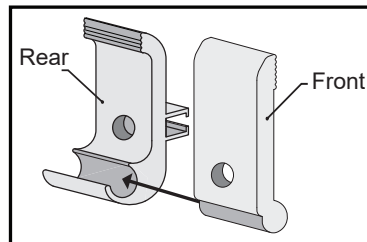

- Slide the Front and Rear Clamps together.

#### STEP 2

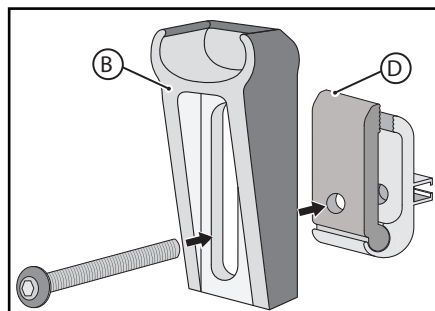

- Attach the Clamp (D) to the Patented Adjustable Bar Bracket (B) as shown.

#### STEP 3

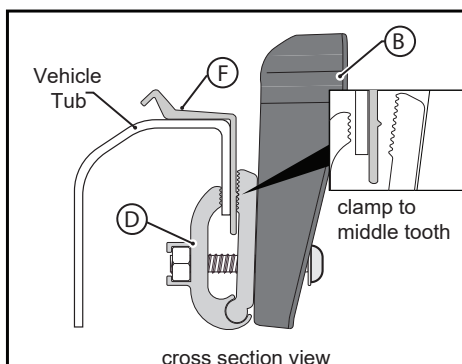

- Engage the now assembled Bar Bracket & Clamp to the Side Rails as shown in the next steps.

## 2

## ATTACH THE SIDE RAILS.

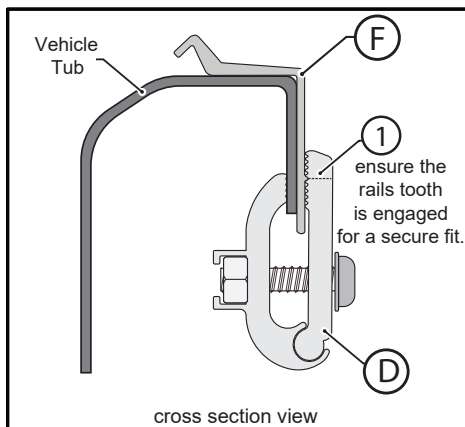
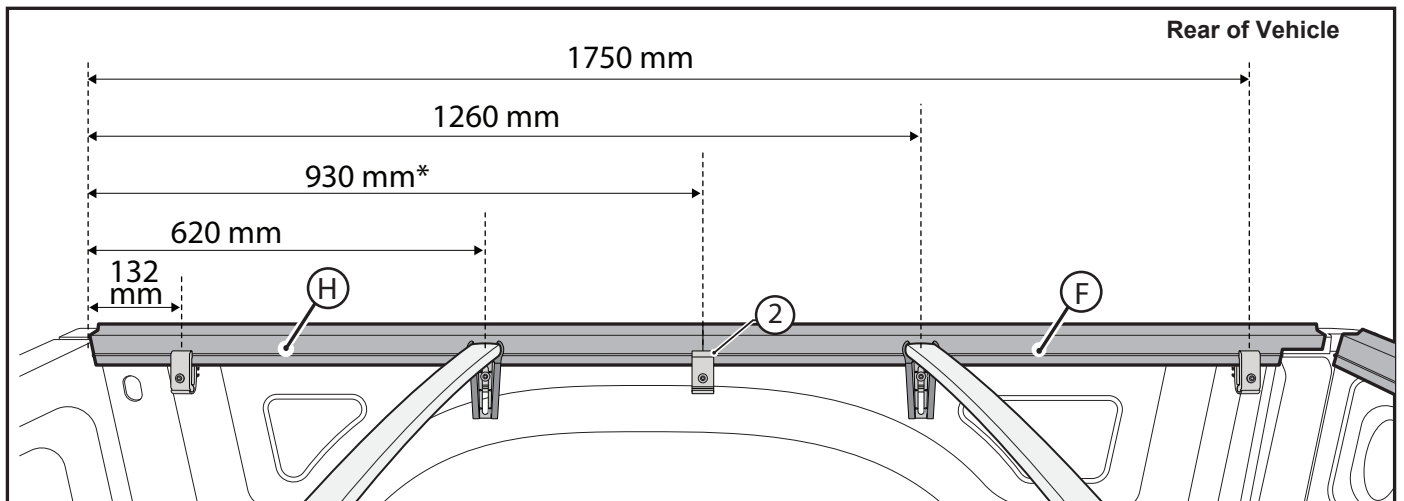

### Important



The side clamp (D) needs to engage with the side aluminium rail tooth (1) for a secure fit.

### Important



The centre side clamp (2) positioned at ~930mm is used to butt up the two aluminium rails (H) (F).

- Repeat for the LHS.

## 3

## FIT THE SUPPORT BARS.

- Front Bar (1) is longer than rear bar (2).

- Rotate the Support Bar (C) 90° and push into the top of the Adjustable Bar Bracket (B).

- Ensure it is seated firmly into place by pushing lightly in the centre of the Support Bar (C).

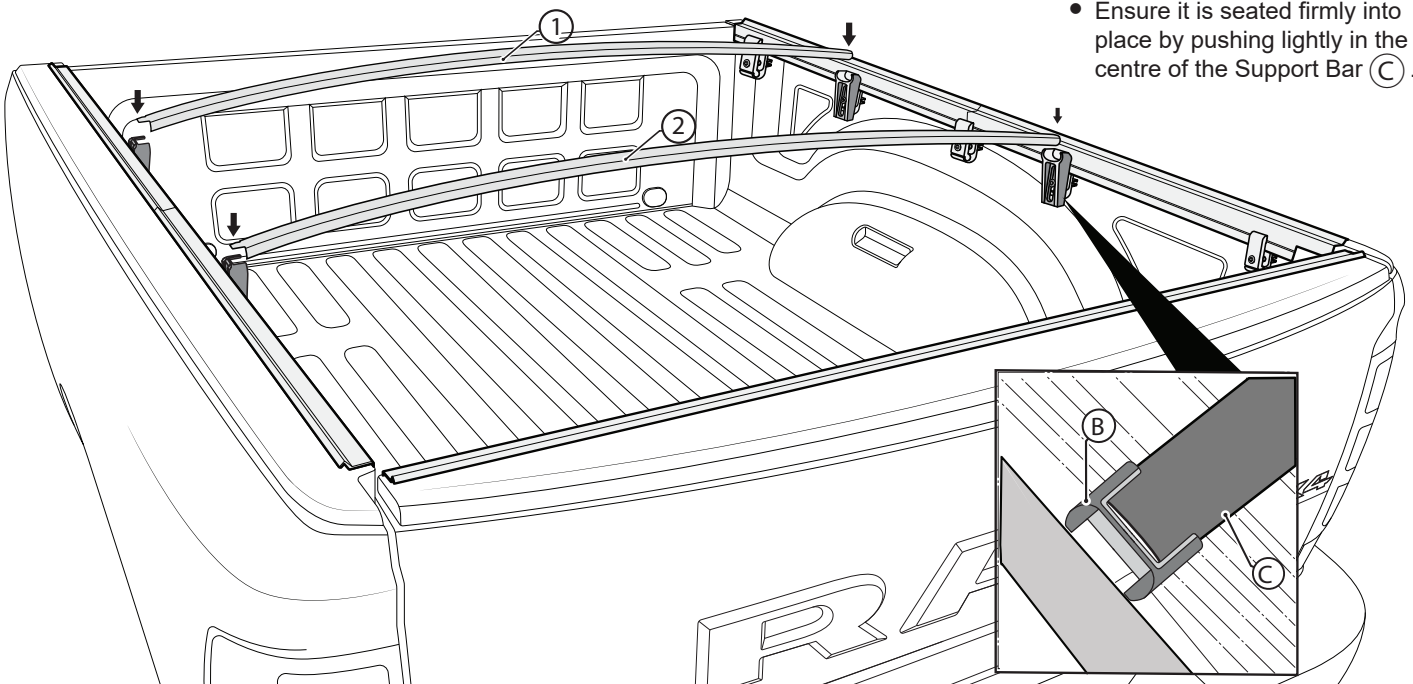

# 4

## PREPARE THE TAILGATE

- Remove the inspection panel by unscrewing all 8 screws (1) using the provided multi tool.

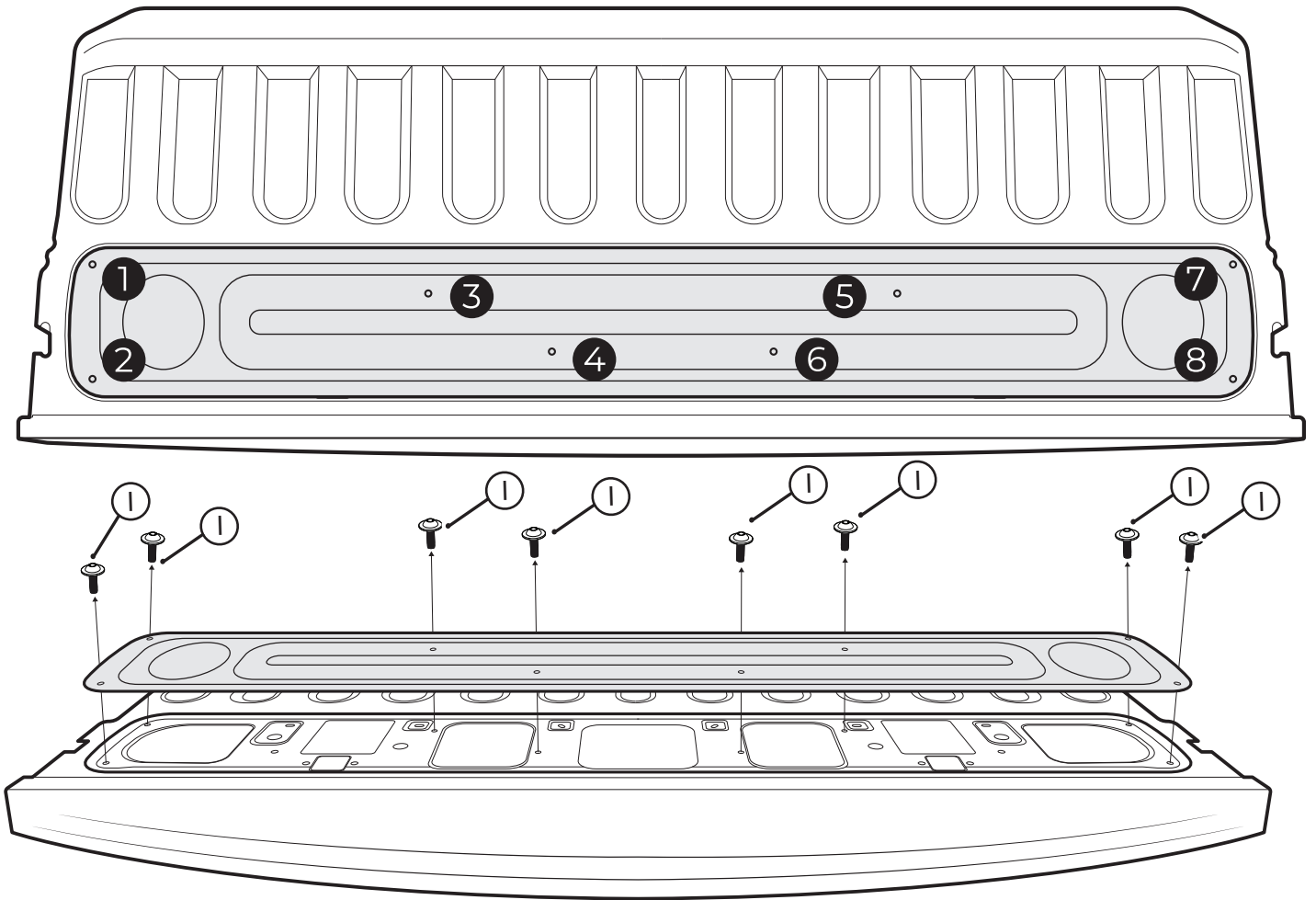

- Remove all 6 plastic inserts (2) from the top of the tailgate using the provided multi tool.

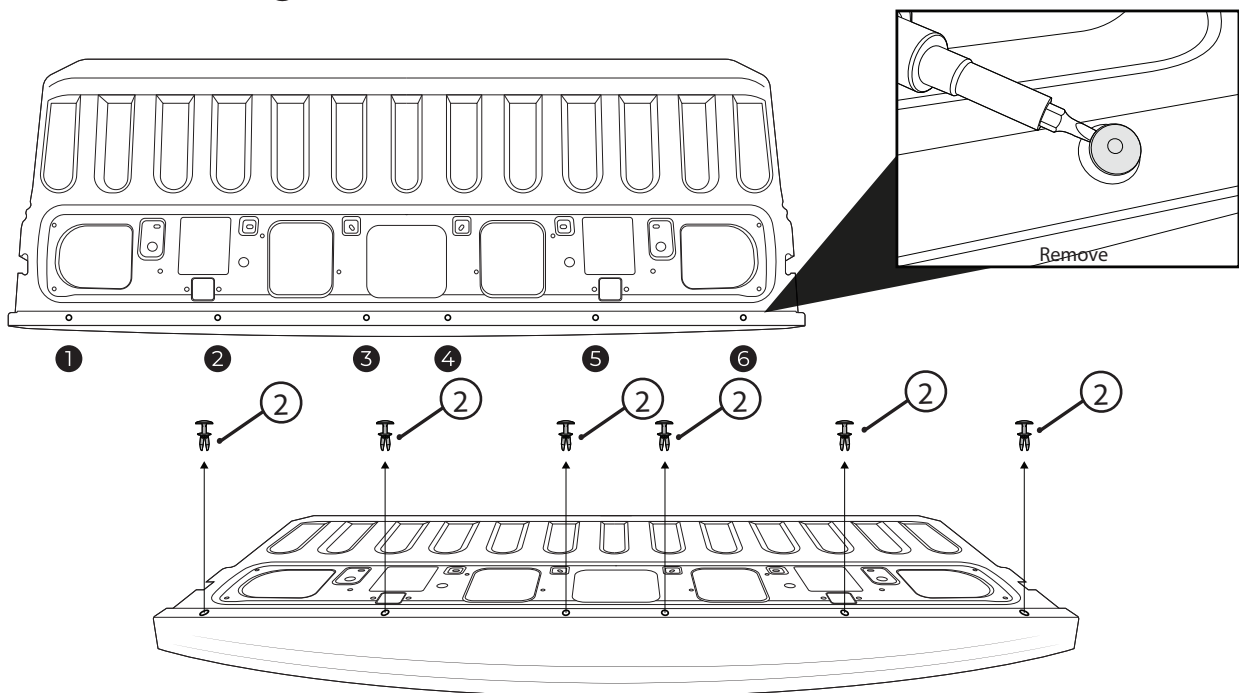

# 5

## ATTACH THE TAILGATE RAIL

- Fit the Tailgate Rail (G) onto the tailgate. Line up the holes on Tailgate Rail (G) with the holes in the tailgate.

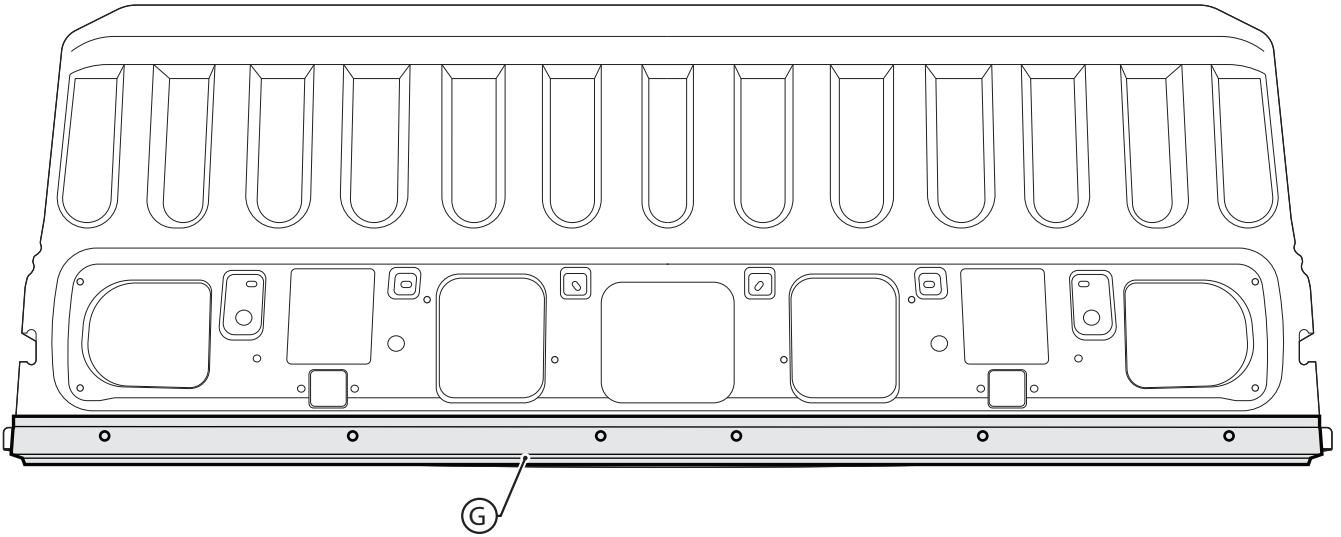

- Place a supplied M6 Bolt (I) through all six of the tailgate rail holes.
- Next place a matching M6 Nyloc Nut (M) inside the tailgate inspection panel attaching to each of the six M6 Bolts (I).
- Utilising the provided multi tool and 10mm Spanner, tighten up all six bolts ensuring the aluminium is secured to the tailgate.

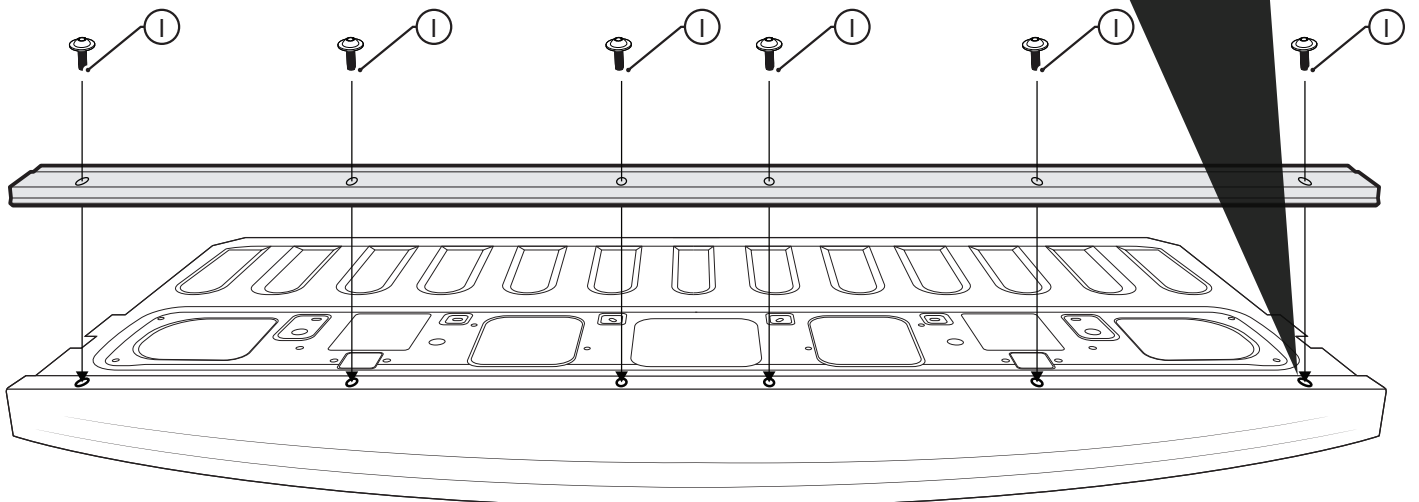
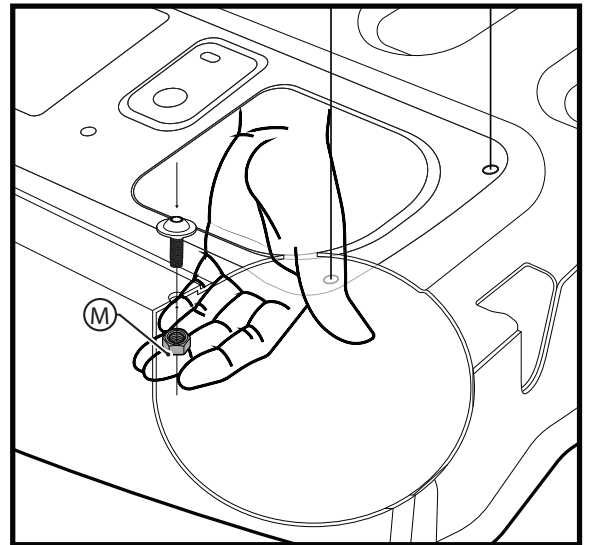

## 6

# REPLACE THE INSPECTION PANEL

- Replace the inspection panel and screw all 8 screws ① using the provided multi tool.

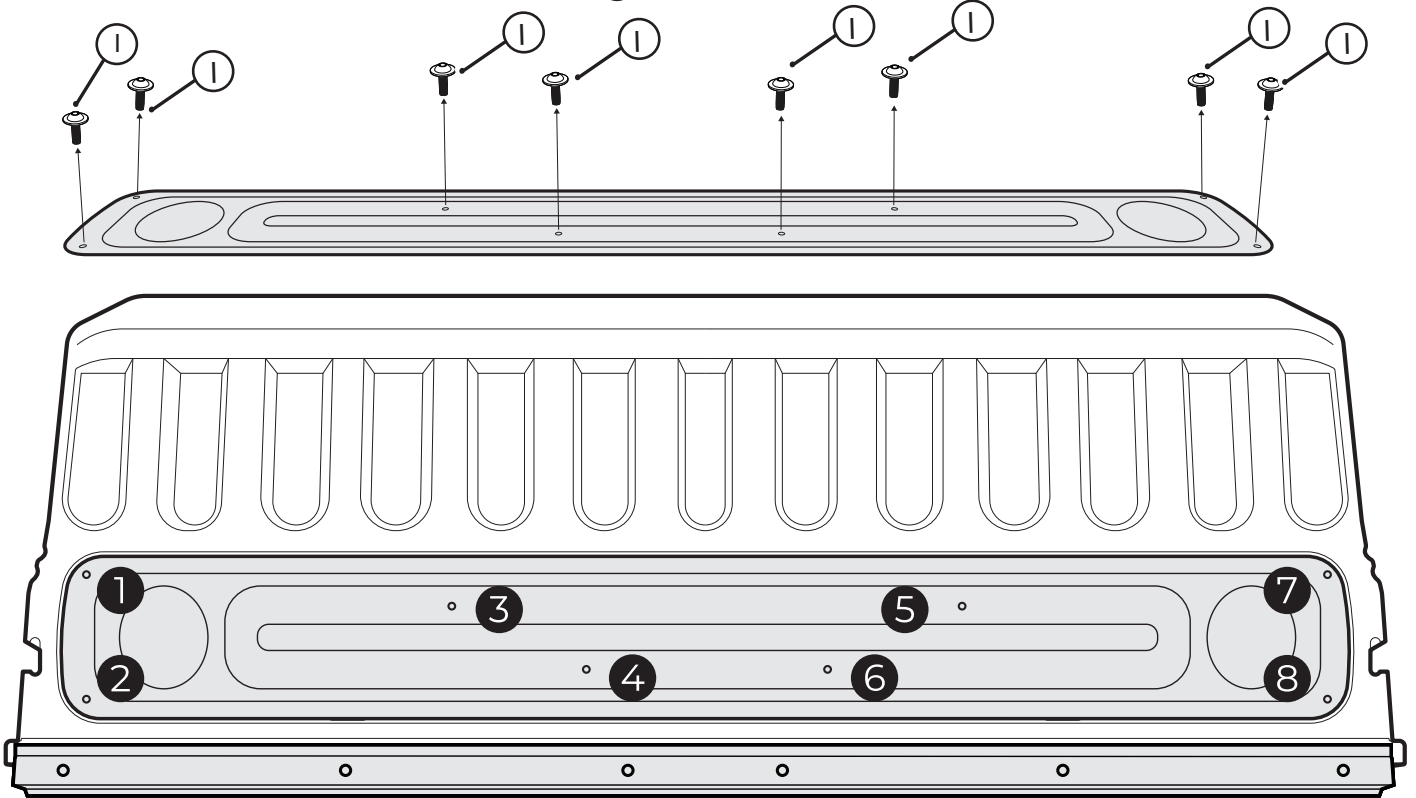

## 7

# FIT THE TONNEAU COVER

- Attach the plastic J Retainer on the front of the Tonneau Cover (A) to the front lip of the Ute tub located behind the cab window.
- Engage the back of the cover first, followed by the sides.

**Note:** Ensure the support bar is fitted underneath the Tonneau Cover to prevent water ingress and to keep the cover tight.



Use the pull tabs to assist whenever you open or close your cover.

**Note:** Fitment will be tight straight out of the box, but this should loosen up a little after a week or so.

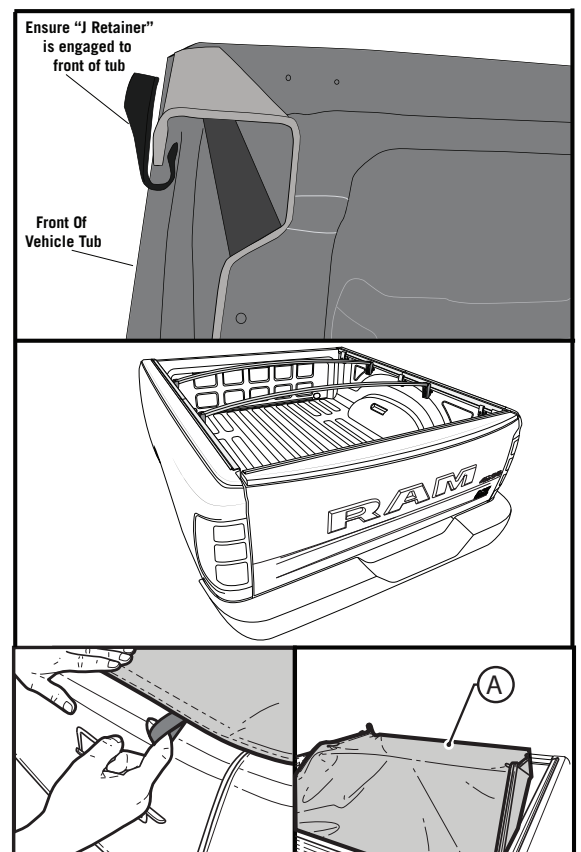

## ADJUSTING THE TENSION OF THE COVER

- To adjust the tension of the cover, you must adjust the height of the support bar. To do this, we have designed a patented adjustable bracket system which will allow you to freely adjust the height to any position within the range of the bracket.
- Simply loosen the bolt which goes through the Bar Bracket (C) and Clamp (E), then move the bracket either up or down until the bolt is at your desired level. Re-tighten the bolt.
- Your Adjustable Bar Bracket has a large tension range.
  - “L” lowers the height and loosens the cover.
  - “H” increases the height and tightens the cover.

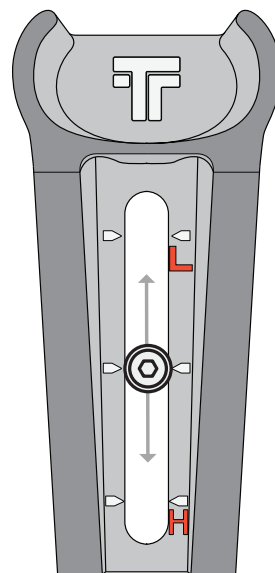

“L” set here if cover is tight and hard to clip on.

“H” set here if cover is loose or if water is pooling on it.

---

**CONGRATULATIONS!**  
**YOU HAVE SUCCESSFULLY INSTALLED YOUR**  
**CLIPON 2.0<sup>®</sup> TONNEAU COVER**



# HOW TO USE THE OVERSIZED LOAD SYSTEM

## STEP 1

- Place the load into the ute tub then drape the tonneau cover over it as shown.

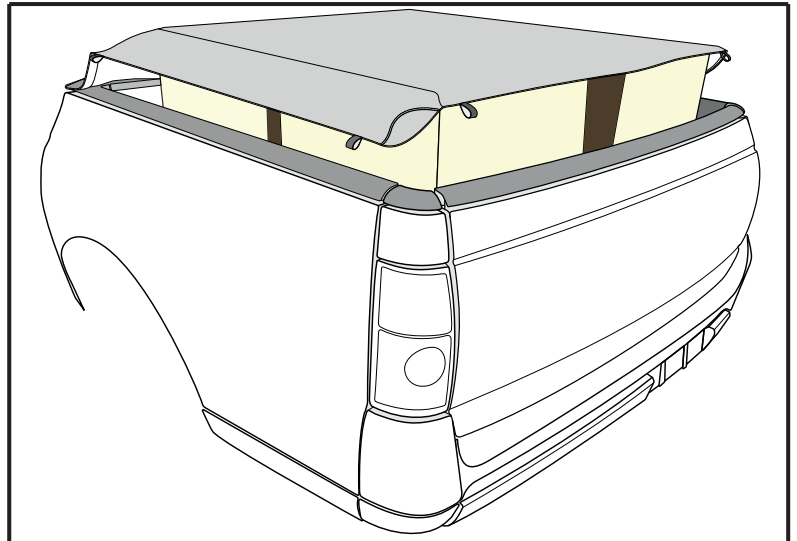

## STEP 2

- Engage the Rope Hooks from underneath the Tonneau Cover and clip each one onto either the Tub Rail (Holden Commodore/Crewman) or Aluminium Rail (all other vehicles).

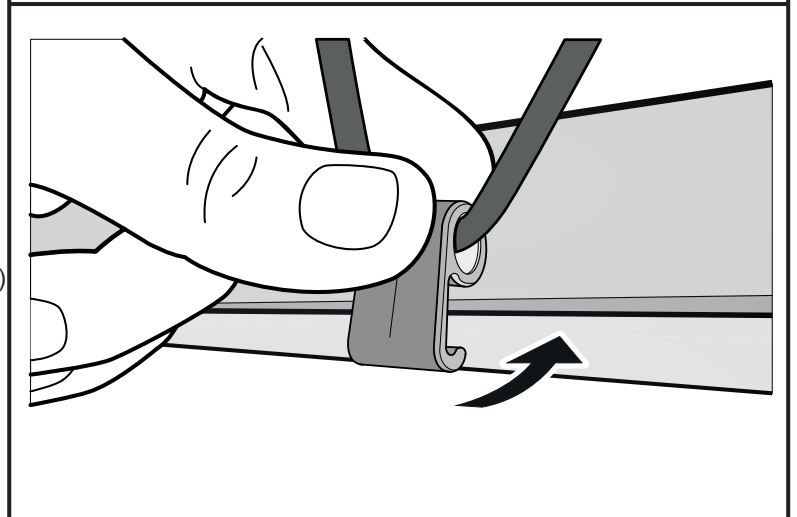

## STEP 3

- Engage all Rope Hooks for a secure fit.

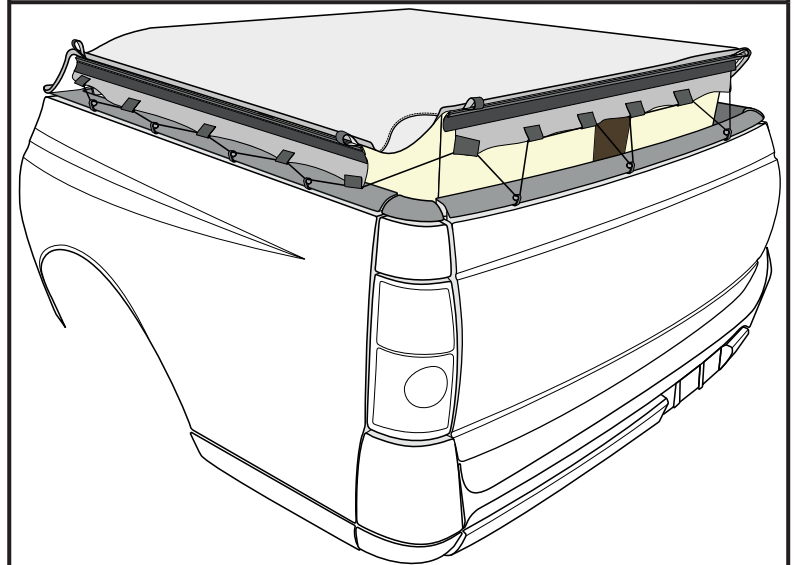

Important



The Tonneau Cover is not designed to be a load restraint. You **MUST** securely tie down your load first and then use the Oversized Load Cover System.

# TONNEAU COVER TETHERING SYSTEM

## STEP 1

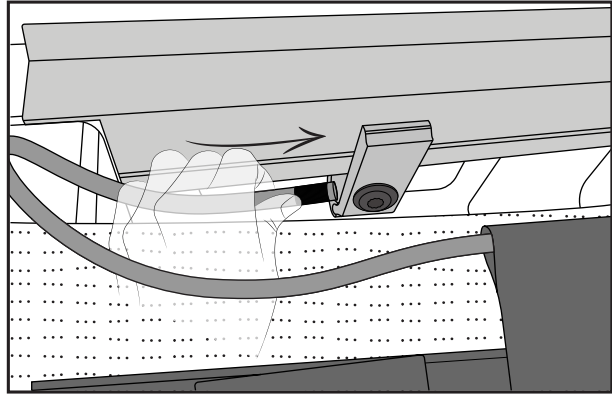
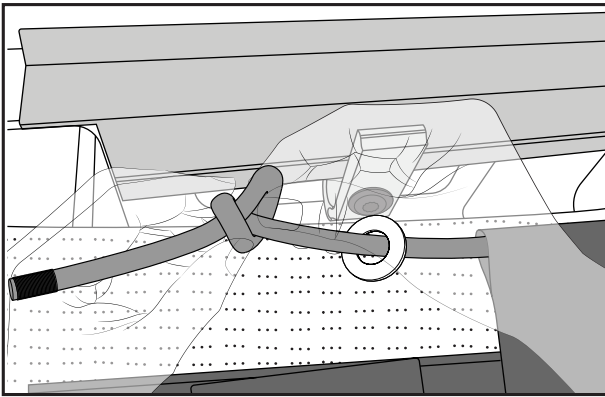

- Unclip the drivers side section of the cover from the aluminium rail.
- Untie the knot and remove the washer.
- Thread the rope through the clamp located near the front of the tub.

## STEP 2

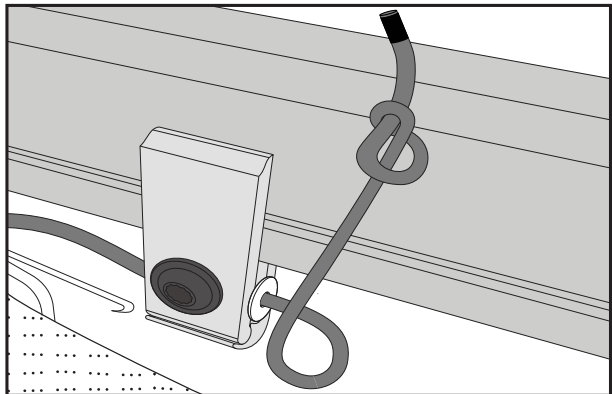
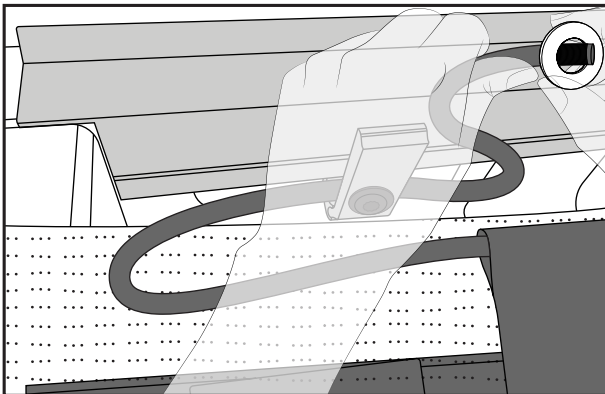

- Rethread the washer and tie the end of the rope in a knot.

## STEP 3

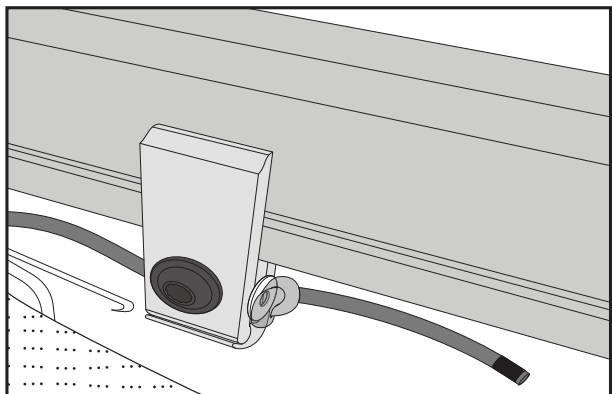
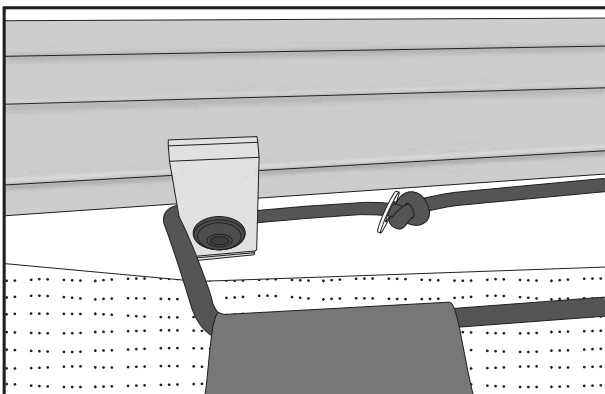

- With the washer in place the rope can not slip past the clamp.
- Repeat these steps for the passenger side.



Important

This product must be installed exactly as specified in this installation manual. Failure to do so may result in improper fit which can cause structural damage to the product and vehicle as well as serious accidents due to partial or complete loss of the product and void of warranty.