

TONNEAU FITTING INSTRUCTION

Ford Ranger XLT With Sports Bar

2007-Oct 2011

Part number: 11191

Package includes

<input type="checkbox"/> 1 X Tonneau Cover	<input type="checkbox"/> 2 x Bar Brackets
<input type="checkbox"/> 1 x Tonneau Support Bar	<input type="checkbox"/> 30 x Rivets
<input type="checkbox"/> 3 x Aluminium Rope Track-484mm long ea.	<input type="checkbox"/> 1 x Lock Bracket
<input type="checkbox"/> 1 x Support Bar Sheath	<input type="checkbox"/> 18 x Rope Buttons
<input type="checkbox"/> 1 x Fitting Instructions	<input type="checkbox"/> 2 x Dowel
	<input type="checkbox"/> 18 x Anti-Abrasive Discs

1. TONNEAU COVER FITTING

NOTE Read entire instructions prior to start.

1.1 BASIC TOOL REQUIRED

Drill, 4mm Drill Bit, Rivet Gun, Marking Pencil / Pen

1.2 TONNEAU COVER INSTALLATION PROCEDURE

STEP 1: Fit Rope Track

Using two pieces of dowel join the 3 aluminium rope tracks together. Place the other 2 pieces of dowel in the ends of the now joined rope track.

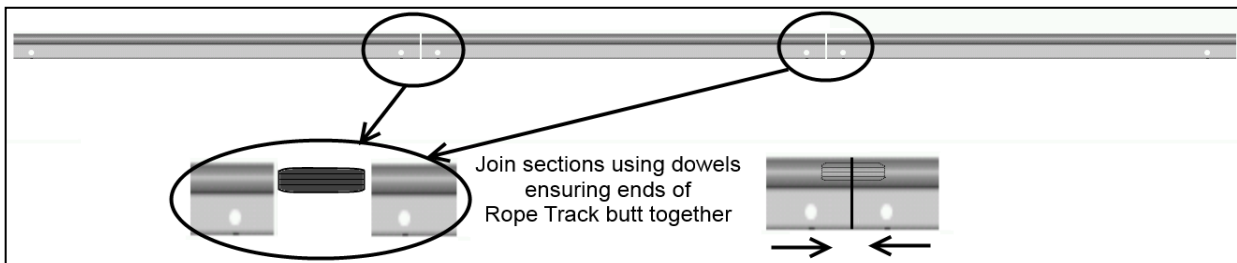

Position the Rope Track centralised ON TOP of the front of the tub, 22mm in front of the base of the Sports Bar. The opening needs to face forward, towards to cab.

Using a 4 mm drill bit, drill 6 holes 50mm from the end of each of the aluminium rope tracks into the top of the tub.

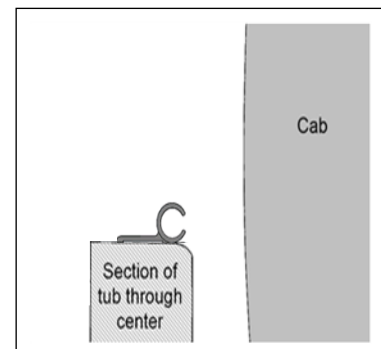

Once all the holes have been drilled, remove the dowelling pieces. Squeeze silicon sealant along the back of the rope tracks and pop rivet into place.

STEP 2: Fit Support Bar

Measure 765mm from the inside tailgate edge forward along the driver's side.

Place centre of Bar Bracket at this point with the top of Bar Bracket 5mm down from top edge of tub.

Using the Bar Bracket as a guide, drill into the body.

Rivet the Bracket in place and repeat for Passenger's Side.

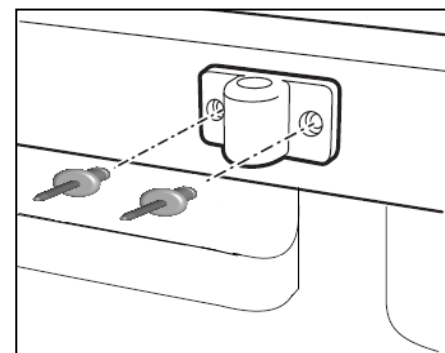

Refer to section 3 of this instruction to install the Adjustable Support Bar.

Insert Support Bar

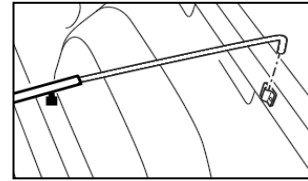

STEP 3: Fit Buttons to Tailgate

Slide the front of the tonneau cover through the aluminium rope track section and drape tonneau cover over the support bar & tub, making sure the cover is centred.

Vertically line up each hook individually to each bunji loop and drill and rivet the round buttons in line 395mm up from the bottom edge of the Tailgate. Attach bunjis to hooks as they are fitted.

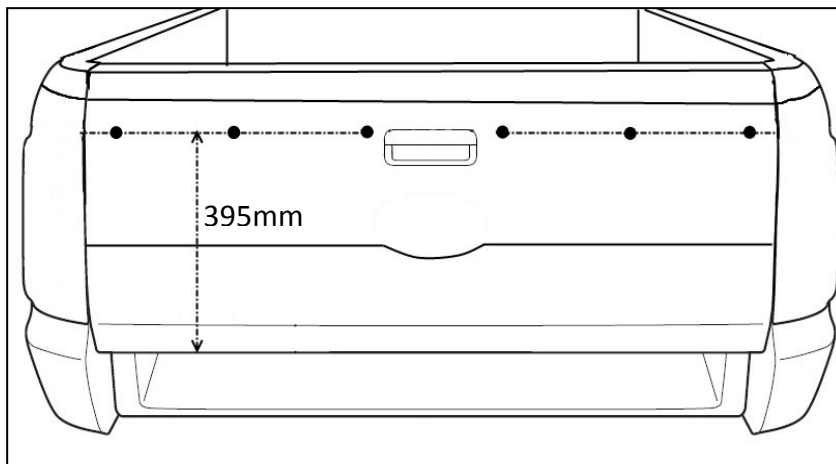

STEP 4: Fit Buttons to Sides

Line up each hook individually to each bunji loop. The first bunji at the rear side of the car is 120mm down from the top **inside** edge.

Drill and rivet round body hooks, alternating from side to side from back to front. The remaining buttons are 140mm down from the top **inside** edge.

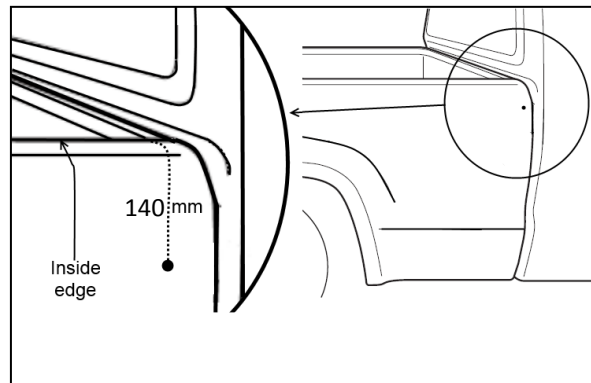
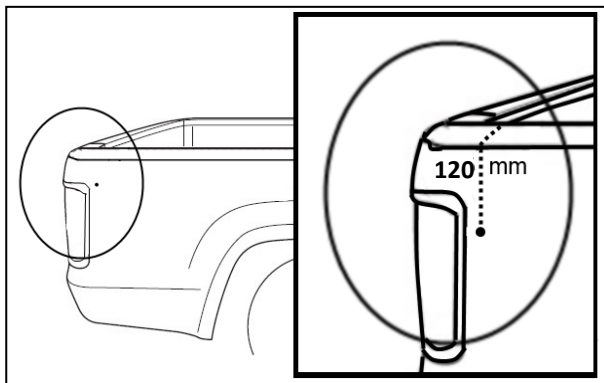

2. TONNO LOCK

The Tonno Lock is now a standard feature included with all Tuff Tonneaus. The Tonno Lock is situated at the front of the tonneau cover, so as not to impede the accessibility of the Tuff Tonneau.

Fitting the lock is simple and only requires a small attachment on the inside edge of the tub behind the cab. Together with a padlock, it provides you with an extremely effective theft deterrent. The Tonno Lock is designed to suit

all utes and prevent thieves stealing your Tuff Tonneau, so you can continue to rely on the Tuff Tonneaus' name to give you what you want in a tonneau cover.



2.1 BASIC TOOL REQUIRED

Rivet gun, Drill, Torch, and Marking Pencil/Pen.

You will need to buy a small Padlock- make sure the padlock will go through the hole on the Tonno lock.

2.2 TONNO LOCK CONTENTS

- 2 X 4MM Aluminium rivets
- 1 x Tonno Lock bracket

2.3 FITTING TONNO LOCK

1. Attach the black lock bracket to the bracket on the tonneau with your padlock, and fit the tarp.
2. Getting under the tarp with a torch, place the lock bracket against the body and mark holes with a pen.
3. Remove tonneau and drill the marks with a 4 mm drill bit, place the lock bracket in position and rivet.

3. MULTI-FIT SUPPORT BAR

The Tuff Tonneau Multi - Fit Support Bar is designed to fit almost all Utes on the Market, from Suburu Brumbys to Cab Chassis aluminium trays.

Part No: 300516



3.1 BASIC TOOL REQUIRED

Drill, 4mm drill bit

3.2 MULTI-FIT SUPPORT BAR CONTENTS

- 1 x hollow bar centrepiece
- 2 x grub screws
- 2 x solid bar end piece
- 1 x Tonneau bar sheath

3.3 FITTING MULTI-FIT BAR

1. Insert solid bar pieces into either end of hollow tube. Adjust bar so it fits between bar bracket holders with the holes facing to the ground (so the grub screws don't rub against the tonneau), as shown above and then with a white pencil make a mark through the small holes of the hollow bar onto the solid ends. This is where you will drill a hole to the depth of about 1-2mm (do not go any further)
2. Join the pieces back together and screw grub screws through the hollow bar into the holes that you drilled. **Make sure you do not over tighten the grub screws**. Then place the tonneau sheath over the bar to stop the bar wearing against the tonneau. Refit the bar. You may kink the bar in the middle to give it some extra height to assist with water runoff.

Warning if you do not fit the tonneau sheath over the bar, the tonneau cover will quickly wear through which is not covered by warranty.

4. WARRANTY AND FEEDBACK

Please register your warranty details online at:

QR Code:



Website Link:

<http://www.tto.com.au/en-au/warranty.html>

Please complete our 2 minute feedback section as we strive to constantly improve for our customers.

Your Tuff Tonneau is now ready for work.