

TONNEAU INSTALLATION INSTRUCTION

Mitsubishi MQ/MR Triton Club Cab Without Headboard and Sports Bar

July 2015 – Current

Part number: 10969

Package includes

1 X Tonneau cover	4 x Bar Brackets
2 x Tonneau Support Bar	38 x Rivets
2 x Support Bar Sheath	1 x Lock Bracket
1 x Tailgate Rail (1400mm)	1 x Inhibitor
2 x Side Rail (1780mm)	1 x Fitting Instructions

1. TONNEAU COVER FITTING

NOTE: Read entire instructions prior to start. Apply rust inhibitor to all drilled holes prior to riveting.

1.1 BASIC TOOL REQUIRED

Drill, 4mm Drill Bit, Rivet Gun, Marking Pencil / Pen

1.2 TONNEAU COVER INSTALLATION PROCEDURE

1. Sit the flat side of the rope track on the top front edge of the tub with the 'C' channel facing forward. *See Figure 1*

2. Align the front of the 'C' channel with the outside edge of the top edge of the tub.

3. Centralise the rope track.

4. With a 4mm drill bit, Drill 5 x 4mm holes evenly spaced in the rope track and into the top edge of the tub. *See Figure 2*

5. Place a 4mm rivet in each hole as it is drilled, but do not rivet.

6. Once all holes have been drilled, remove the rivets and rope track and clean any swarf away.

7. Apply a bead of silicone to the flat face of the rope track (the edge that comes in contact with the top edge of the tub) and place the rope track back in position. *See Figure 3*

8. Rivet into place.

9. To attach the side aluminium rails, clean the top surface of the tub walls. Remove the red backing tape from the rail.

10. Align the inside edge of the rail with the inside driver's side edge of the tub pushing the side rail up against the ropetrack. Notched ends to the front and rear.

11. Slide each rail down keeping the taped surface square with the top of the tub.

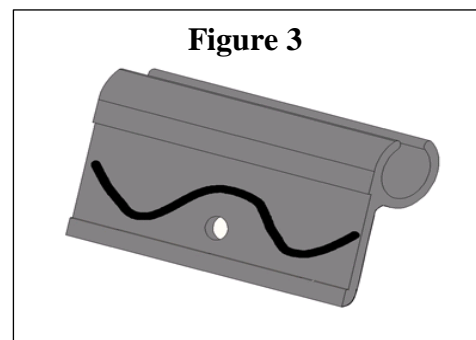
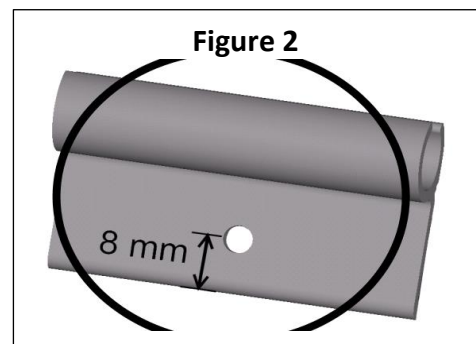
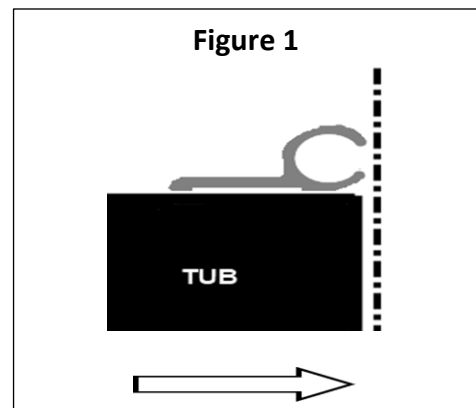

12. Press down firmly to ensure adhesion.
13. Drill 3 evenly spaced holes through each rail into the side of the tub.
14. Rivet each hole once they have all been drilled.
15. Repeat for Passenger Side of vehicle.

16. To attach the tailgate, measure and mark the centre of the tailgate and rail with non-permanent marker.
See Figure 4

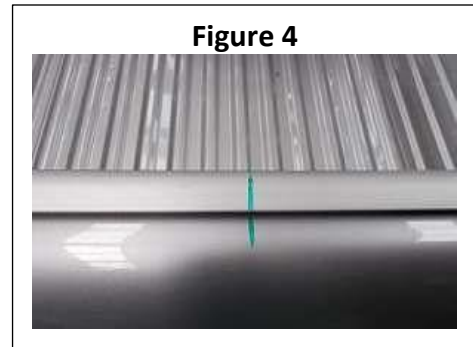

17. Measure and mark on the flat surface of the rail, 25mm from each end, the centre, and 335mm each side of centre. All holes will be 5mm from the bottom edge of the rail.

18. Remove the red backing tape from the rail then match the two centre marks (one on the tub, and one on the rail) and stick the rail flat on to the tailgate.

19. Drill and rivet the aluminium to the tailgate to complete attachment.

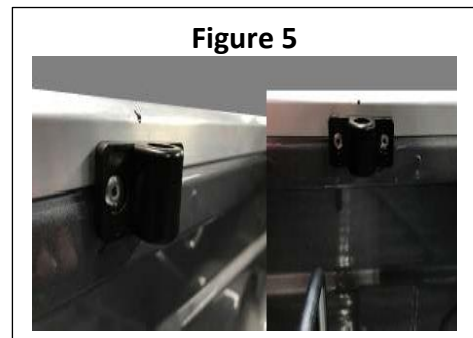

20. To attach the bar brackets, measure 600mm and 1200mm back from the inside front edge of the tub and place them as shown in the images (**Figure 5**).

21. The hole in the bar bracket will sit just below the bottom edge of the side rail. Drill and rivet using two rivets for each Bar Bracket.

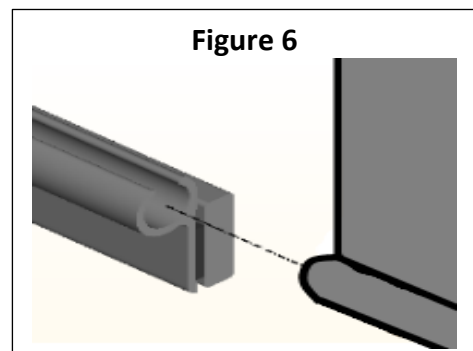

22. Fit support bar refer to section 3.

23. To attach the cover, slide the front rope of tonneau cover into the ropetrack channel and centre the cover. **See Figure 6**

24. Pull the cover over support bar and drape the cover across the tub.

25. Clip the rear of the cover onto the tailgate rail, then clip the sides onto the side rails. **See Figure 7**

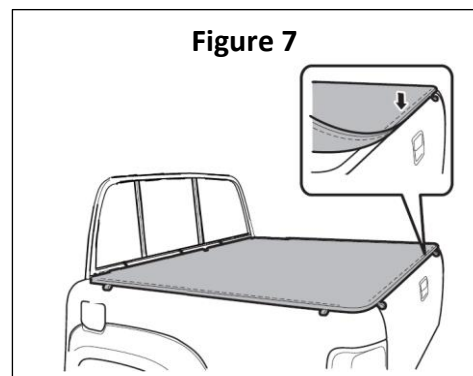

Using Internal Elastic Shock Cord:

The plastic clips on the internal shock cord can be hooked into the aluminium rails so that the cover can still be secured with larger loads in the tub.

NOTE: You can adjust your tonneau, to make it tighter or looser, by simply raising or lowering the height of your tonneau support bar.

2. TONNO LOCK

The Tonno Lock is now a standard feature included with all Tuff Tonneaus. The Tonno Lock is situated at the front of the tonneau cover, so as not to impede the accessibility of the Tuff Tonneau.

Fitting the lock is simple and only requires a small attachment on the inside edge of the tub behind the cab. Together with a padlock, it provides you with an extremely effective theft deterrent. The Tonno Lock is designed to suit all utes and prevent thieves stealing your Tuff Tonneau, so you can continue to rely on the Tuff Tonneaus' name to give you what you want in a tonneau cover.



2.1 BASIC TOOL REQUIRED

Rivet gun, Drill, Torch, and Marking Pencil/Pen.

You will need to buy a small Padlock- make sure the padlock will go through the hole on the Tonno lock.

2.2 TONNO LOCK CONTENTS

- 2 X 4MM Aluminium rivets
- 1 x Tonno Lock bracket

2.3 FITTING TONNO LOCK

1. Attach the black lock bracket to the bracket on the tonneau with your padlock, and fit the tarp.
2. Getting under the tarp with a torch, place the lock bracket against the body and mark holes with a pen.
3. Remove tonneau and drill the marks with a 4 mm drill bit, place the lock bracket in position and rivet.

3. MULTI-FIT SUPPORT BAR

The Tuff Tonneau Multi - Fit Support Bar is designed to fit almost all Utes on the Market, from Subaru, Brumby's, to Cab Chassis and aluminium trays.



3.1 BASIC TOOL REQUIRED

Drill, 4mm drill bit

3.2 MULTI-FIT SUPPORT BAR CONTENTS

- 1 x hollow bar centrepiece
- 2 x grub screws
- 2 x solid bar end piece
- 1 x Tonneau bar sheath

3.3 FITTING MULTI-FIT BAR

1. Insert solid bar pieces into either end of hollow tube. Adjust bar so it fits between bar bracket holders with the holes facing to the ground (so the grub screws don't rub against the tonneau), as shown above and then with a white pencil make a mark through the small holes of the hollow bar onto the solid ends. This is where you will drill a hole to the depth of about 1-2mm (do not go any further)
2. Join the pieces back together and screw grub screws through the hollow bar into the holes that you drilled. **Make sure you do not over tighten the grub screws.** Then place the tonneau sheath over the bar to stop the bar wearing against the tonneau. Refit the bar. You may kink the bar in the middle to give it some extra height to assist with water runoff.

Warning if you do not fit the tonneau sheath over the bar, the tonneau cover will quickly wear through which is not covered by warranty.

4. WARRANTY AND FEED BACK

Please register your warranty details online at:

QR Code:



Website Link:

<https://www.tto.com.au/en-au/warranty.html>

Please complete our 2 minute feedback section as we strive to constantly improve for our customers.

Your Tuff Tonneau is now ready for work.