

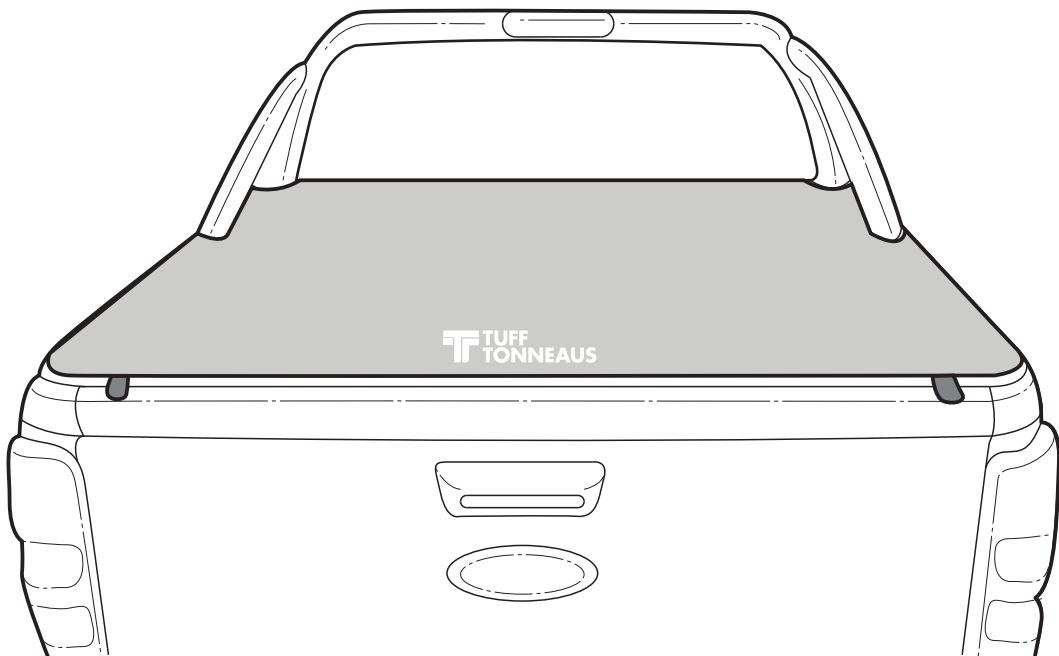

CLIPON 2.0[®]

INSTALL INSTRUCTIONS



FACTORY SPORTS BAR MODELS

– PARTS SUPPLIED

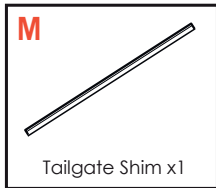
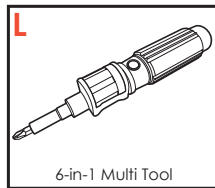
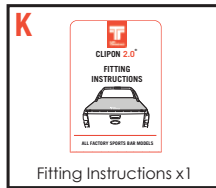
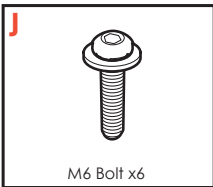
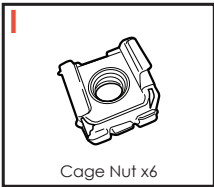
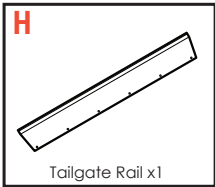
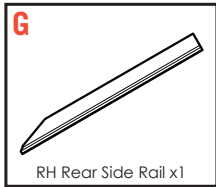
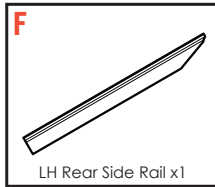
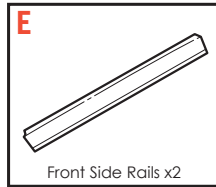
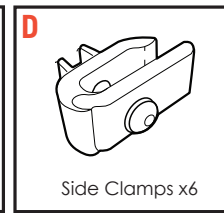
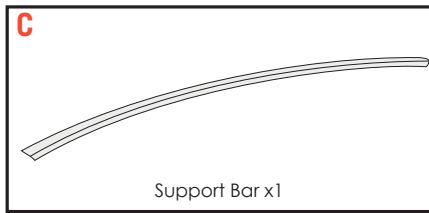
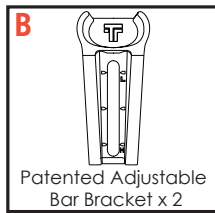
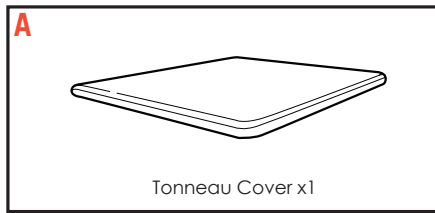

– SAFETY NOTES

- Ensure that appropriate Personal Protective Equipment is used.
- During the accessory fitment, ensure all Australian automotive and dealership safety practices are followed.
- Always refer to vehicle's workshop manual when removing components.



– EXAMPLE FITTING VIDEO

- Please also check out our video of fitting a 2.0 tonneau cover.
- Visit the following link: <http://bit.ly/nodrift-tonneau>
- Or simply scan the QR code.
- NB: Some models may vary slightly in fitment, so always consult your fitting instructions for more information.



- FINAL ASSEMBLY -

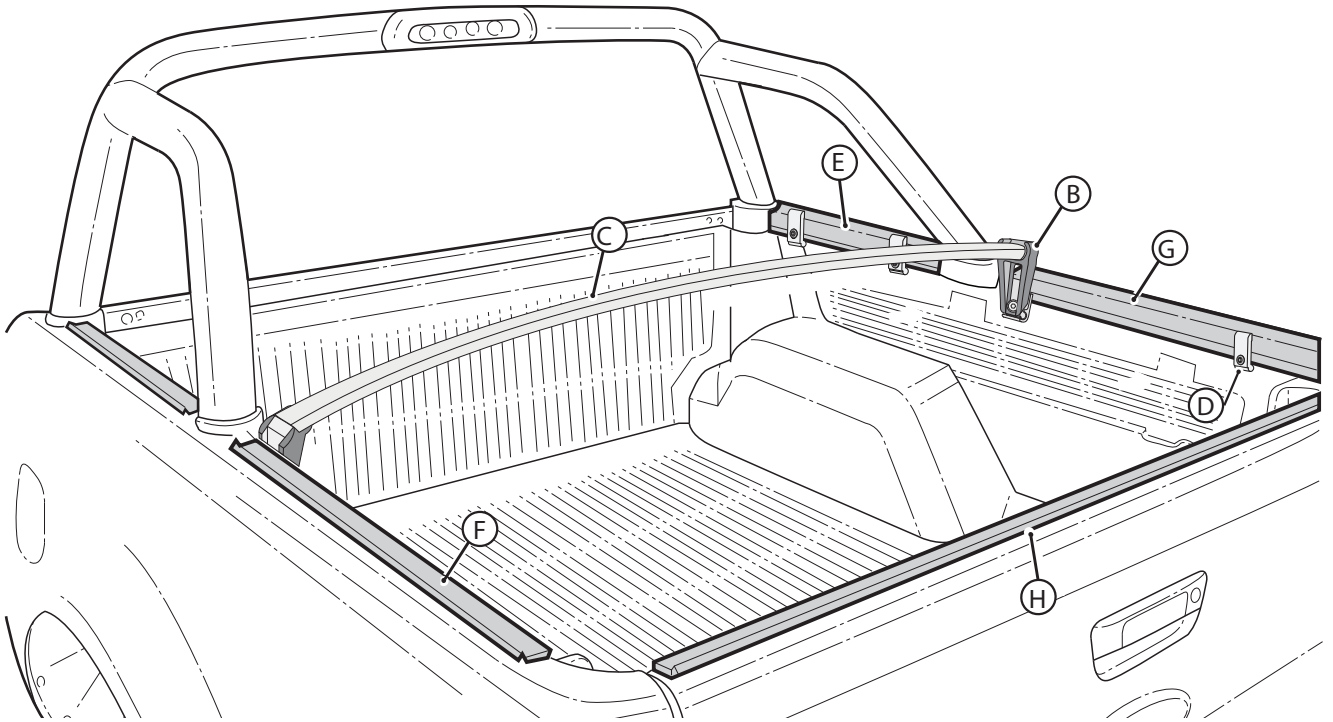

1

ASSEMBLING THE BAR BRACKET

STEP 1

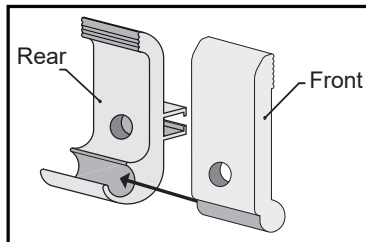

- Slide the Front and Rear Clamps together.

STEP 2

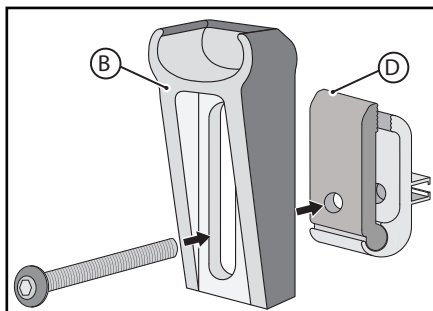

- Attach the Clamp (D) to the Patented Adjustable Bar Bracket (B) as shown.

STEP 3

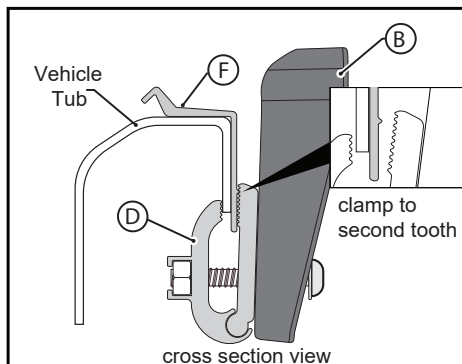

- Engage the now assembled Bar Bracket & Clamp to the Side Rails as shown in the next steps.

2

ATTACH THE FRONT SIDE RAILS

Important



The side clamp (D) needs to engage with the side aluminium rail tooth (1) for a secure fit.

- Repeat for the RHS.

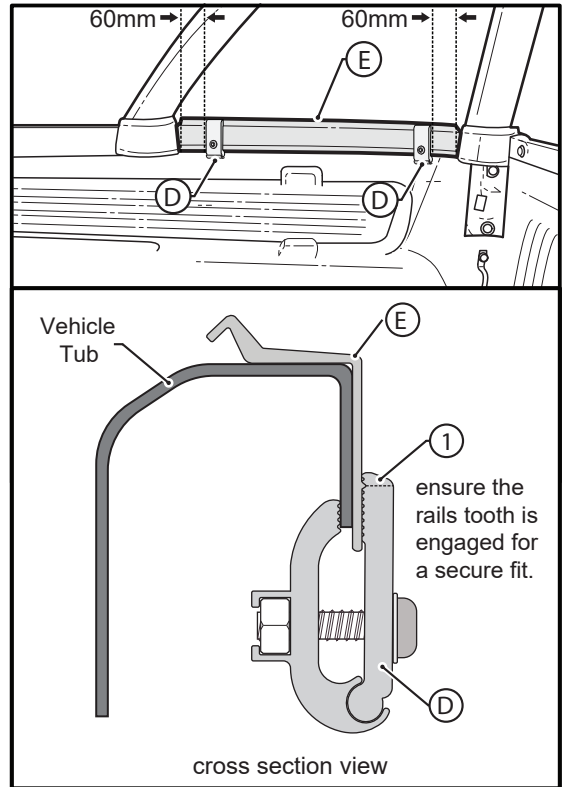

3

ATTACH THE REAR SIDE RAILS

- Place rear side rails (G) flush up against the rear sports bar legs as shown in the figure below.
- Attach one clamp (D) 60mm to 100mm from the rear.
- Repeat for other side rail (F).

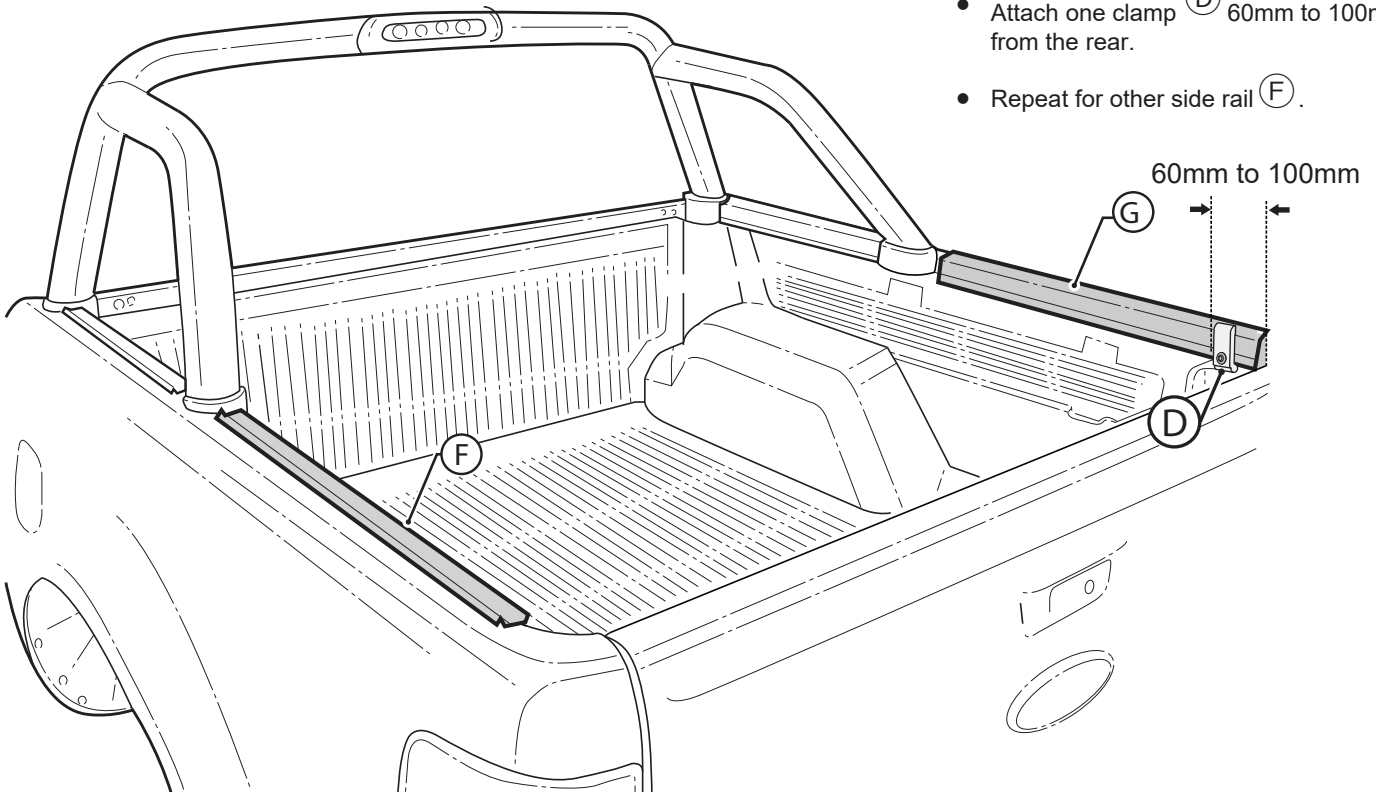

4

FIT THE SUPPORT BAR

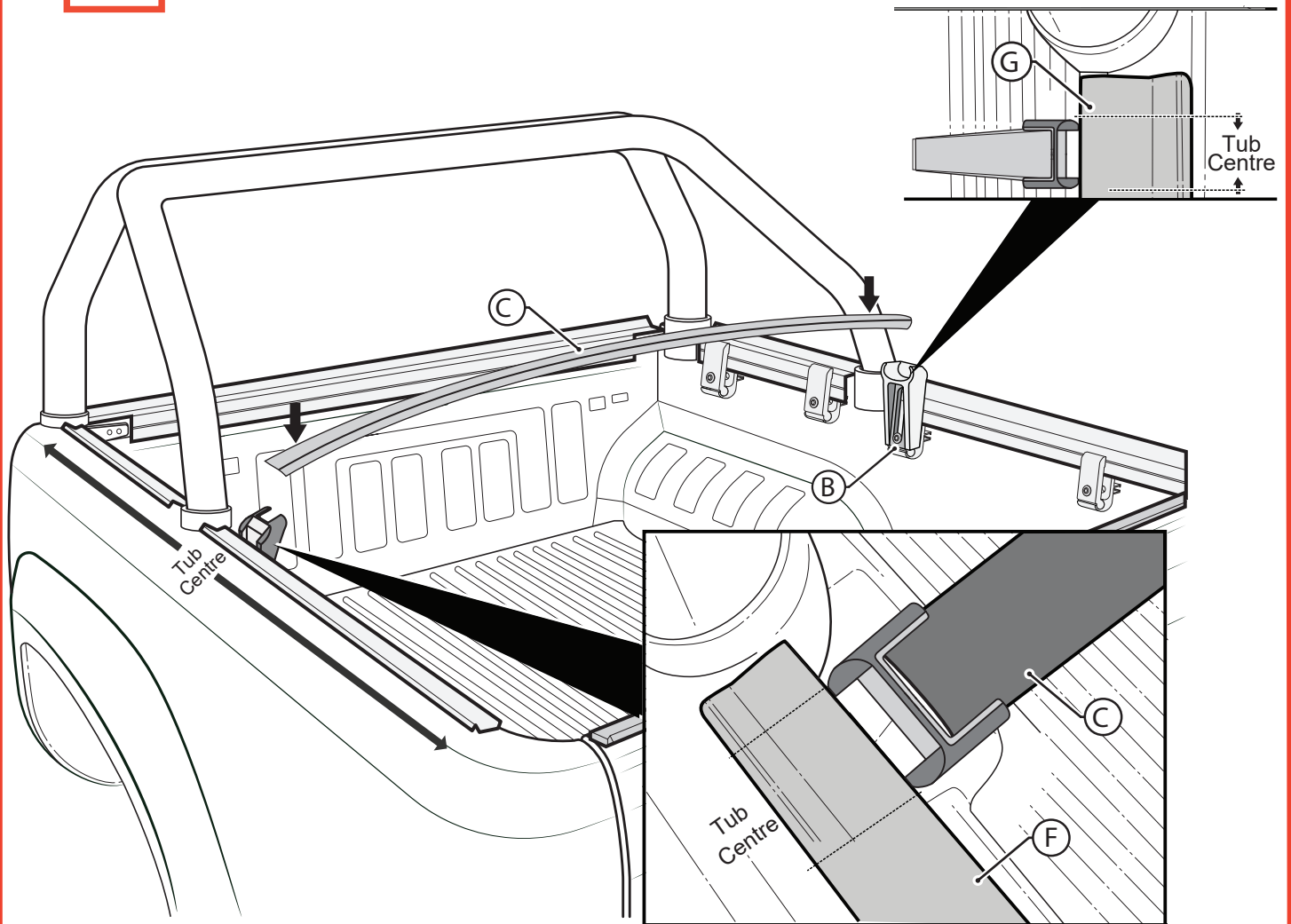

- Ensure the assembled bar bracket and clamp is fitted central to the inside length of the tub to the front of the LH Rear Side Rail (F) and the RH Rear Side Rail (G).
- Rotate the Support Bar (C) 90° and push into the Patented Adjustable Bar Bracket (B).
- Ensure it is seated firmly into place by pushing lightly in the centre of the Support Bar (C).

5 PREPARE THE TAILGATE

- Remove tailgate liner (if fitted), by unscrewing the screws ① and then peeling off the plastic retainer (if fitted).

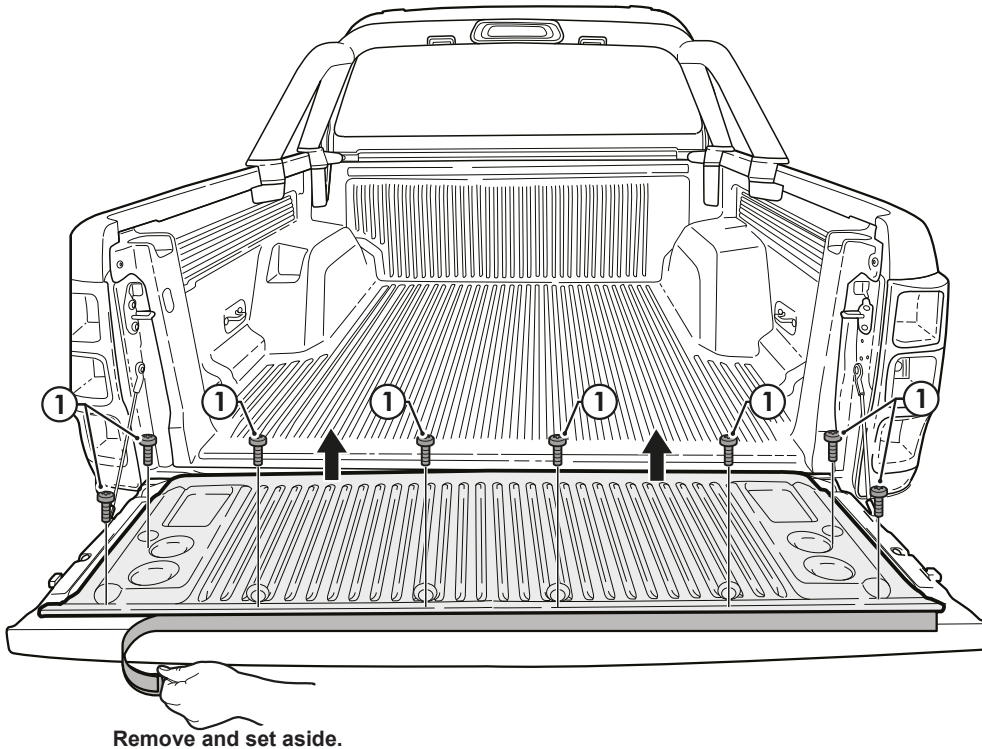

Remove and set aside.

- Remove the inspection panel by unscrewing any remaining screws ②.

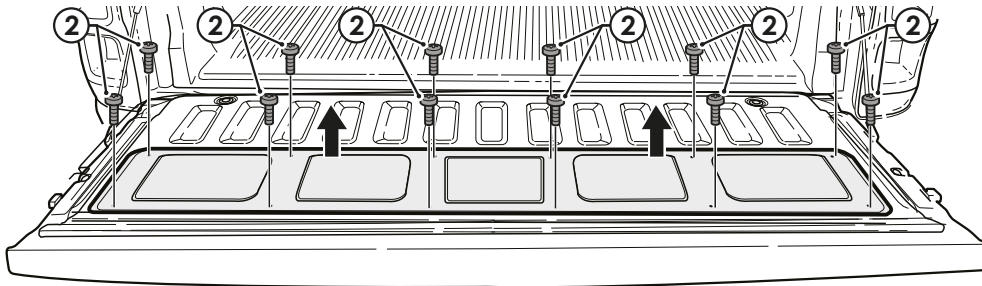

- Remove all plastic inserts ③ from the top row of the inspection panel.

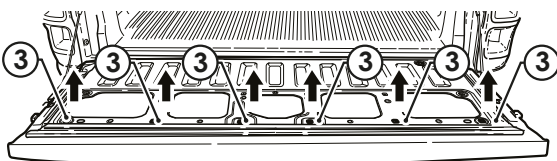
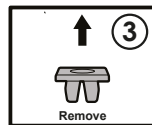

- Where a spray in bed liner is fitted, sometimes there is residual paint material inside the holes which must be cleared. Drill through the inspection panel to create a clearance for supplied bolts to go through using a 7mm drill bit.

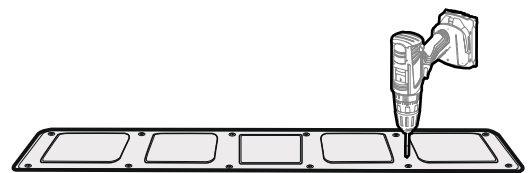

6

FIT THE CAGE NUTS

- Replace the plastic inserts with the supplied Cage Nuts (I).

Note: Fit the cage nuts from the underside of the inspection panel. First engage one leg of the cage nut in the hole and then apply some force and push the other leg of the cage nut so that it fits through the hole.

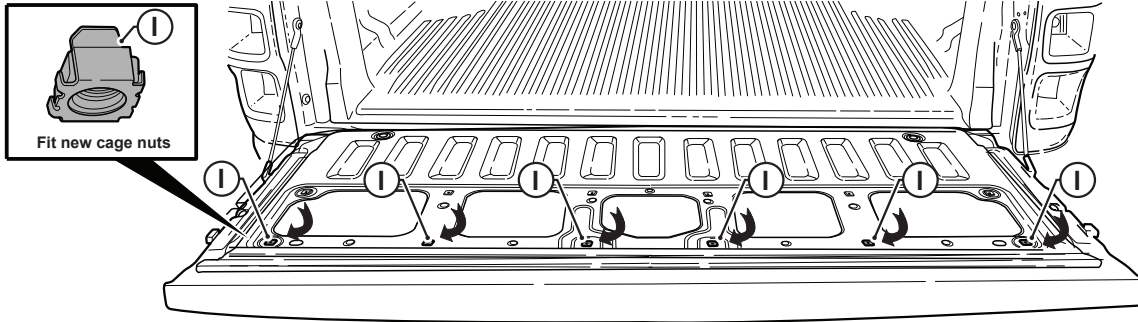

For Vehicles with Ute Liners Fitted Only:

- Without refitting the screws yet, place the inspection panel first, followed by the Tailgate Rail (G), into position on the tailgate. Then put the tailgate liner over the top. Take note of all holes which will be covered over by the tailgate liner. Then set aside.

Note: It may help to mark these holes with a felt pen or pencil.

- For the holes you just marked:
 - Refit original factory screws to the bottom row of the tailgate, as required.
 - Fit M6 Bolts (I) to the Cage Nuts (H) to the top row of the tailgate, as required.

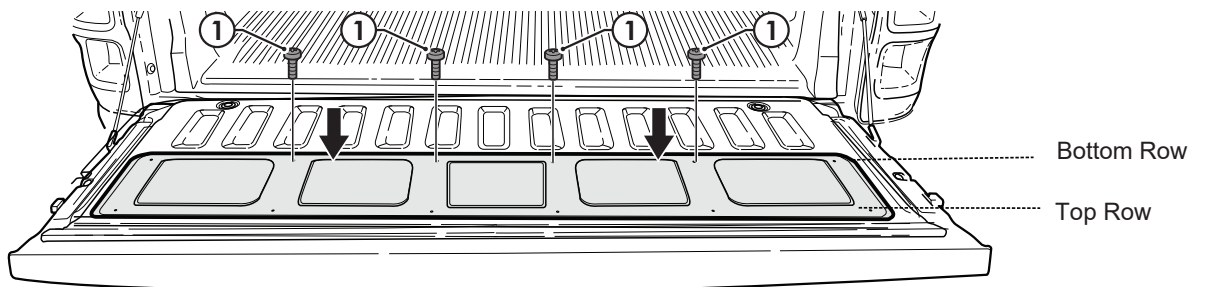

For Vehicles with No Removable inspection Panel Only:

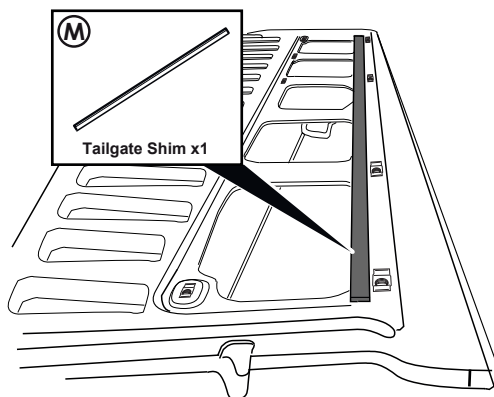

- If there is no inspection panel on the vehicle, peel the backing off the adhesive tape, attached to Tailgate Shim (M). Then position directly below the cage nuts - ensuring distance between the two is no greater than 1mm.

Important  Factory screws must only be refit to plastic inserts. M6 Bolts (I) must be fitted to Cage Nuts (H).

Important  Use VERY low torque when refitting factory screws as there is a risk the thread inside the plastic inserts will strip.

For Vehicles without Ute Liner: Please continue to Step 7.

7

ATTACH THE TAILGATE RAIL

- Fit the Tailgate Rail (H), then place the tailgate liner (if fitted) on top ensuring all holes are aligned.
- Place an M6 Button Head Screw with Collar (J) through the tailgate liner (if fitted), Tailgate Rail (H) and inspection panel and into each of the Cage Nuts, tighten using an allen key.
- If spray in liner is fitted, first install the Tailgate Liner Retaining Strip (M) using the top edge of the inspection panel opening as the datum line, followed by the tailgate rail (H), then tighten down using M6 Button Head screws (J) .

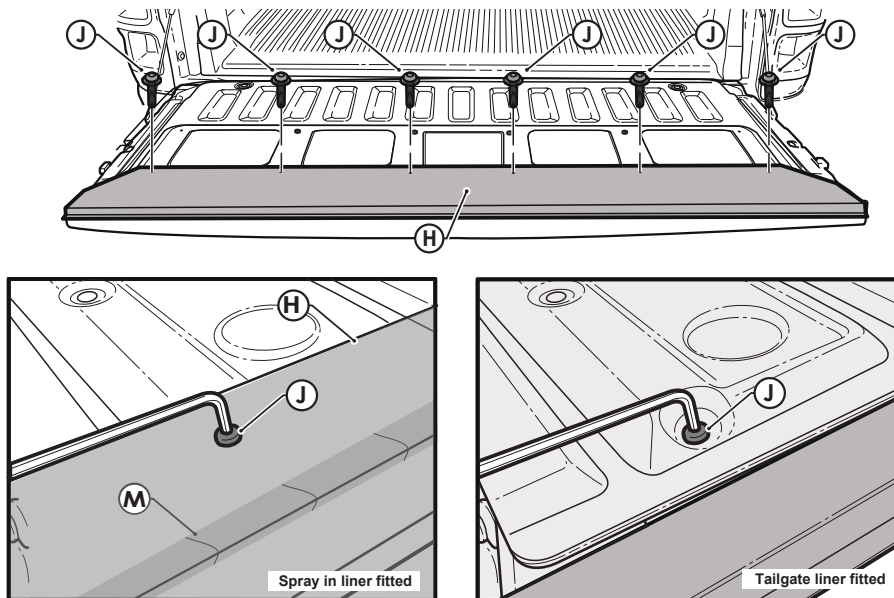

- For vehicle's with tailgate liners, use the original screws (1) and secure the outside edges of the bottom half of the liner.
- Refit the Plastic Retainer Strip which was removed in Step 4 to the edge of the tailgate liner.

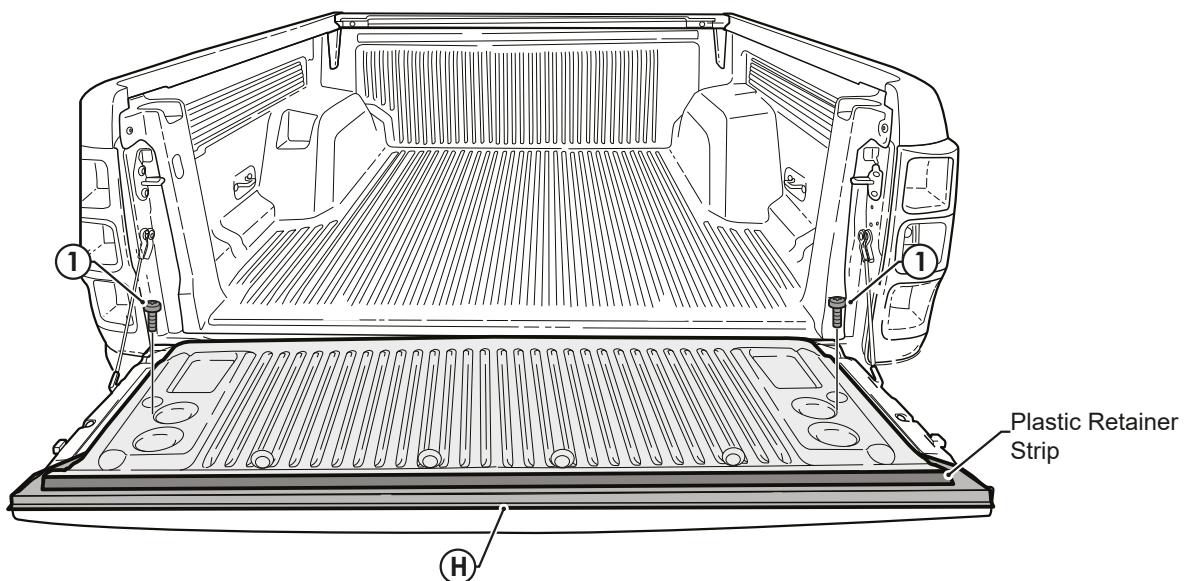

8

FIT THE TONNEAU COVER

- Attach the plastic J Retainer on the front of the Tonneau Cover (A) to the front lip of the Ute tub located behind the cab window.
- Engage the back of the cover first, followed by the sides.

Note: Ensure the support bar is fitted underneath the Tonneau Cover to prevent water ingress and to keep the cover tight.



Use the pull tabs to assist whenever you open or close your cover.

Note: Fitment will be tight straight out of the box, but this should loosen up a little after a week or so.

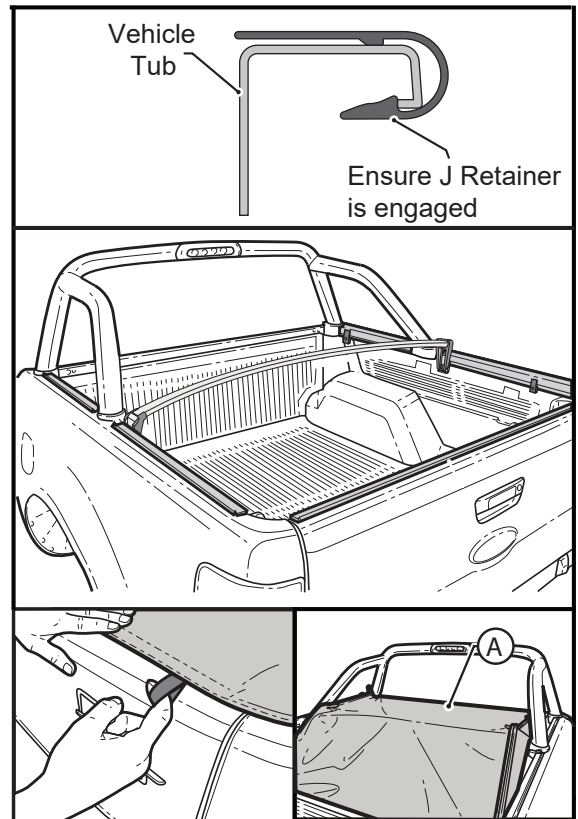

ADJUSTING THE TENSION OF THE COVER

- To adjust the tension of the cover, you must adjust the height of the support bar. To do this, we have designed a patented adjustable bracket system which will allow you to freely adjust the height to any position within the range of the bracket.
- Simply loosen the bolt which goes through the Bar Bracket (C) and Clamp (E), then move the bracket either up or down until the bolt is at your desired level. Re-tighten the bolt.
- Your Adjustable Bar Bracket has a large tension range.
“L” lowers the height and loosens the cover.
“H” increases the height and tightens the cover.



“L” set here if cover is tight and hard to clip on.

“H” set here if cover is loose or if water is pooling on it.

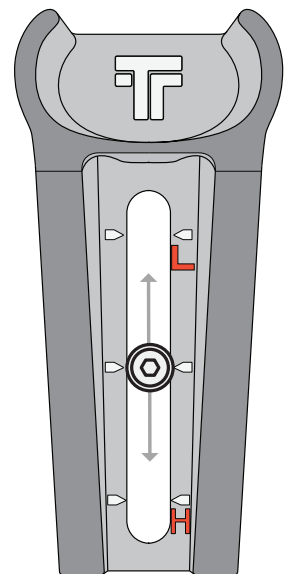

CONGRATULATIONS!
YOU HAVE SUCCESSFULLY INSTALLED YOUR
CLIPON 2.0® TONNEAU COVER

HOW TO USE THE OVERSIZED LOAD SYSTEM

STEP 1

- Place the load into the ute tub then drape the tonneau cover over it as shown.

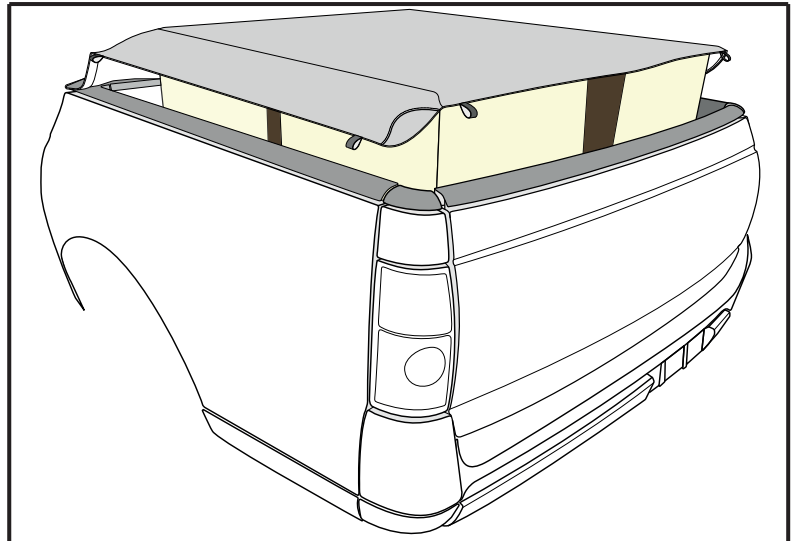

STEP 2

- Engage the Rope Hooks from underneath the Tonneau Cover and clip each one onto either the Tub Rail (Holden Commodore/Crewman) or Aluminium Rail (all other vehicles).

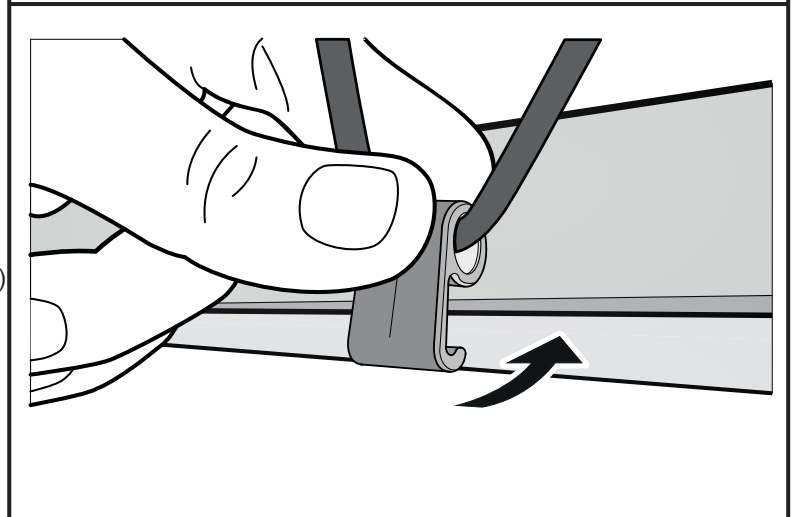

STEP 3

- Engage all Rope Hooks for a secure fit.

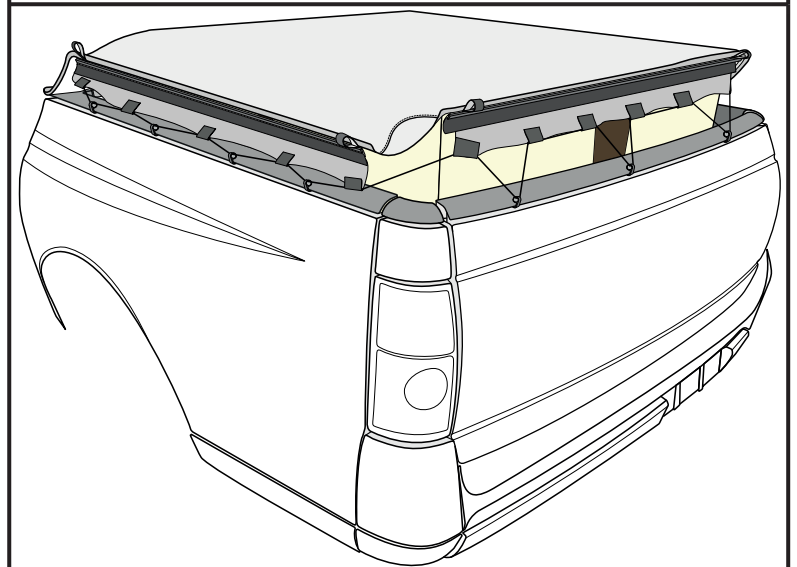

Important



The Tonneau Cover is not designed to be a load restraint. You **MUST** securely tie down your load first and then use the Oversized Load Cover System.