

# TONNEAU FITTING INSTRUCTION

## Ford PX Ranger XL Dual Cab With Headboard

May 2013 - Current

**Part number: 10104**

### Package includes

1 X Tonneau cover	2 x Bar Brackets
1 x Tonneau Support Bar	31 x Rivets
3 x Aluminium Rope Track-476mm long ea.	1 x Lock Bracket
1 x Support Bar Sheath	18 x Rope Buttons
1 x Fitting Instructions	4 x Dowel
1 x Seal Tape 1.6m	1 x Rust Prevention
1 x Seal Template	18 x Anti Abrasive Discs

# IMPORTANT –

THE HEADBOARD ON THIS VEHICLE WAS CHANGED IN MAY 2013.

PLEASE REFER TO THE IMAGE BELOW TO CONFIRM THE HEADBOARD ON THE VEHICLE MATCHES THE IMAGE ON THE RIGHT HAND SIDE.

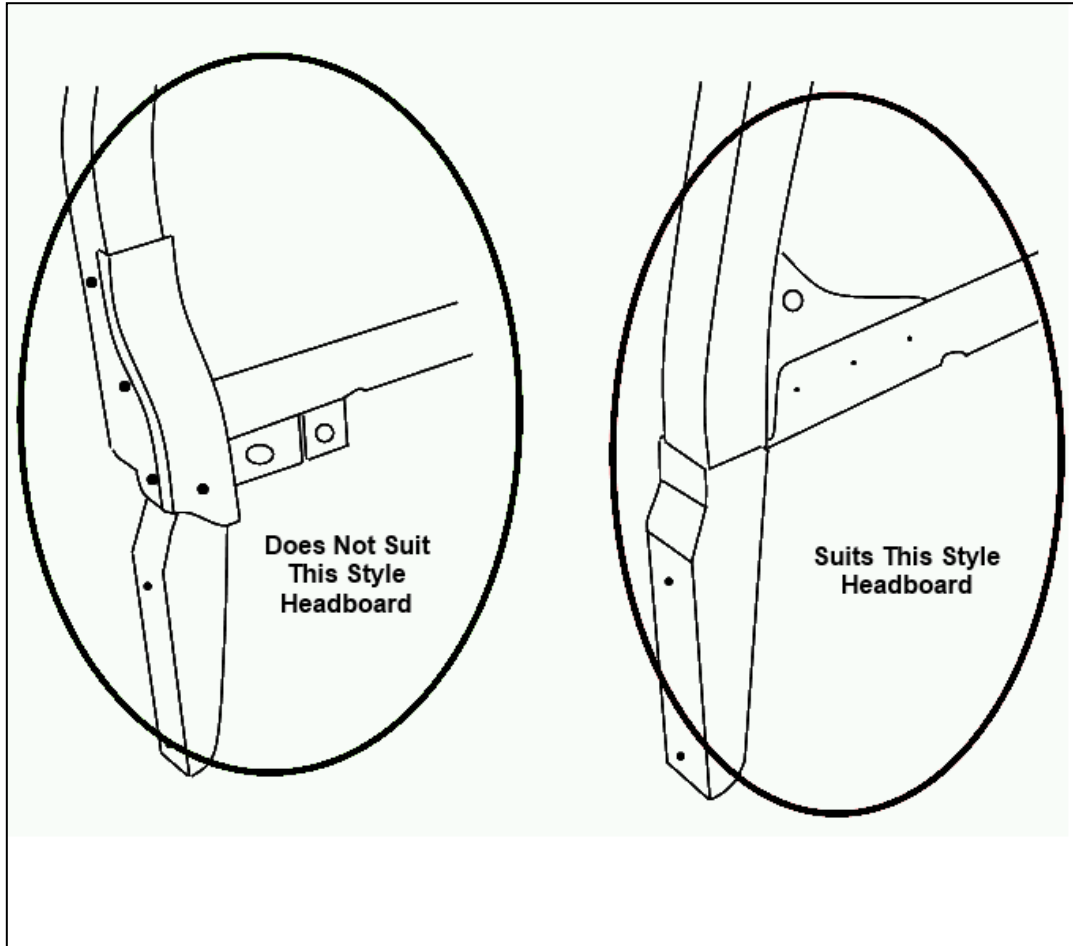

# 1. TONNEAU COVER FITTING

**NOTE** Read entire instructions prior to start.

## 1.1 BASIC TOOL REQUIRED

Drill, 4mm Drill Bit, Rivet Gun, Marking Pencil / Pen

## 1.2 TONNEAU COVER INSTALLATION PROCEDURE

### 1. Fit The Ropetrack

- (a) Using a 4mm drill bit, drill a hole 50 mm in from each end and 9 mm up from the bottom of the 3 pieces of rope track as shown in **Figure 1**.
- (b) Join the 3 pieces of rope track together using the 2 pieces of wooden dowel as shown in **Figure 2**.

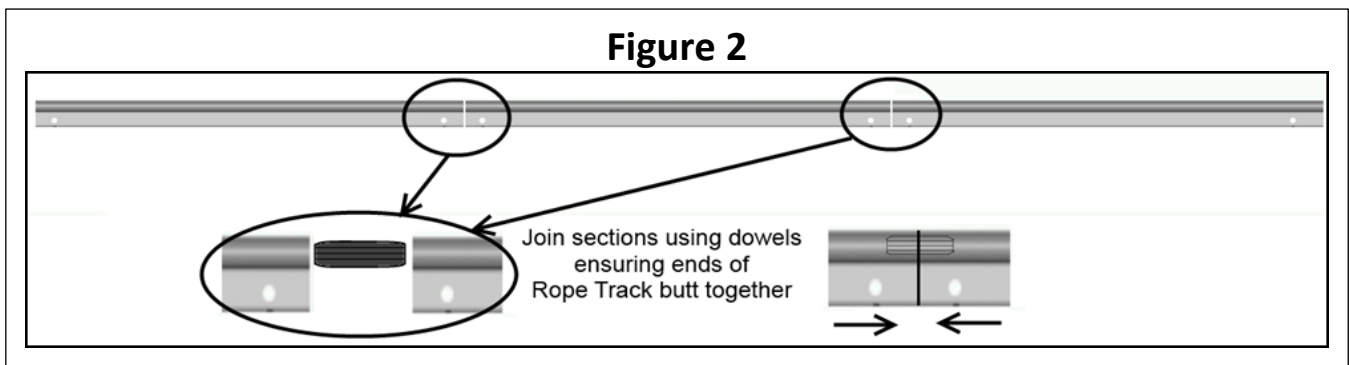
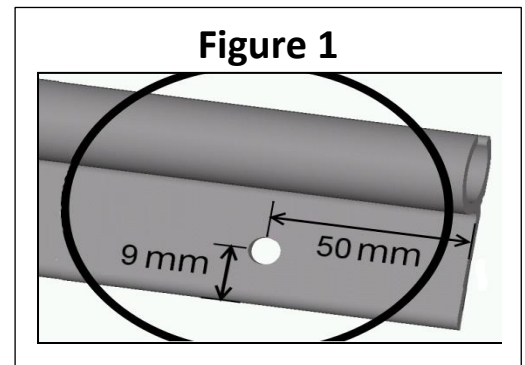

- (c) Sit the flat side of the assembled rope track on the tailgate side of the headboard with the 'C' channel facing upward and align the bottom edge of the rope track with the bottom edge of the headboard then centralise the rope track as shown in **Figure 3**.

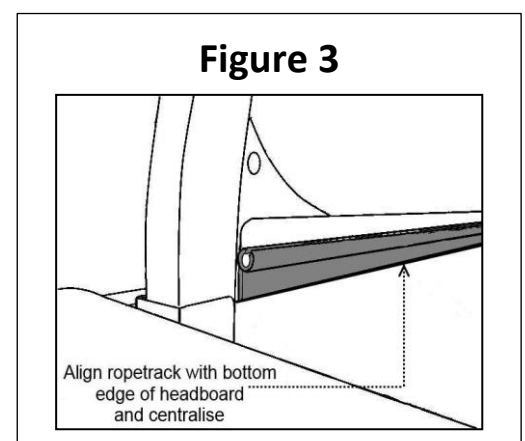

- (d) Drill through the holes in the rope track and into the top edge of the tub working from the centre out, placing a 4mm rivet in each hole as it is drilled, but **do not rivet**.
- (e) Once all holes have been drilled, remove the rivets and disassemble the rope track, discard the dowels and clean any swarf from the tub.
- (f) Apply a bead of silicone to the flat face of the 3 sections of the rope track then rivet the rope track sections into place.

## 2. Fit The Bar Brackets

- (a) Measure 740mm from the inside tailgate edge forward along the driver's side. Place centre of Bar Bracket at this point with the top of Bar Bracket 5mm down from top edge of tub. Using the Bar Bracket as a guide, drill into the body.
- (b) Apply rust inhibitor and rivet the front and rear holes to complete attachment of the Bar Bracket. Repeat for the passenger side of vehicle.

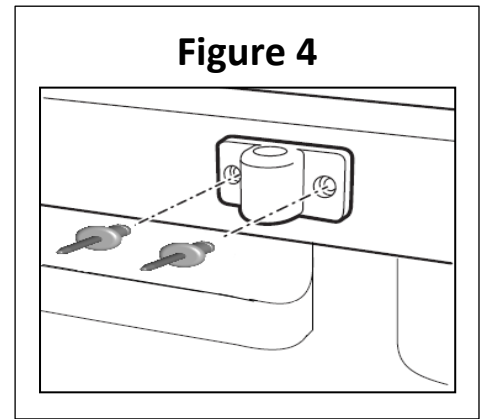

## 3. Fit The Buttons To The Tailgate

- (a) Measure 465mm up from the bottom edge of the tail gate and 25mm, 295mm & 562mm in from the outside edge of the driver's side of the tailgate and mark button positions.
- (b) Repeat for the passenger side of vehicle.
- (c) Drill holes then apply rust inhibitor and rivet buttons into place. *See Figure 5*

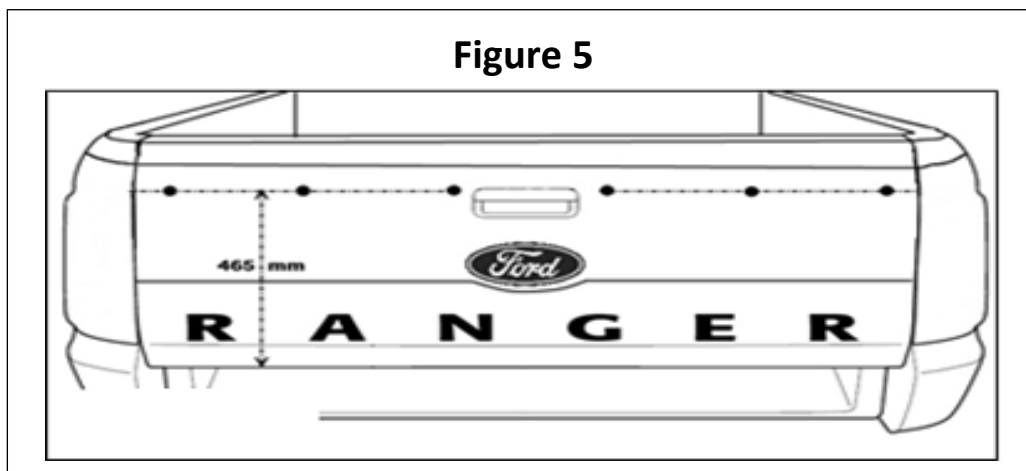

## 4. Fit The Buttons To Driver's Side

- (a) Measure down 165mm from the inside edge of the tub, and back 35mm from the front outside edge of the tub and mark. **This is the position of the front button.** *See Figure 6*

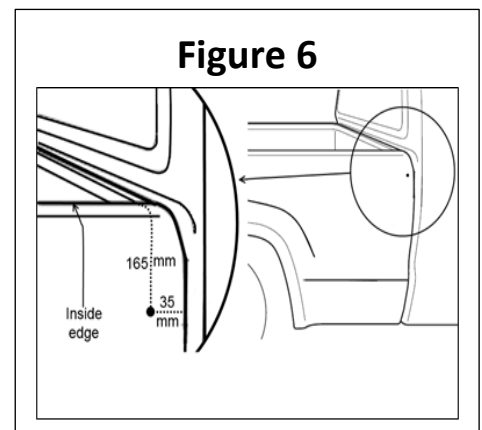

- (b) Measure down **155mm** from the inside edge of the tub, and forward **10mm** from the front outside edge of the taillight and mark. *See Figure 7*

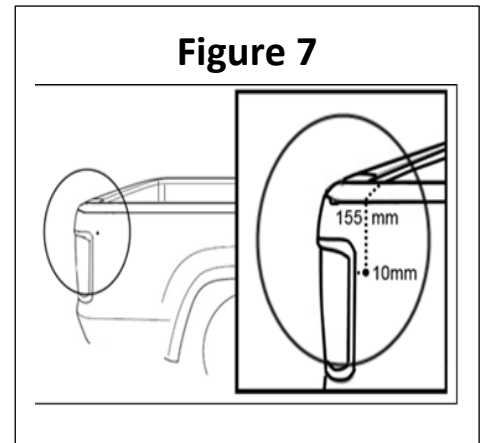

- (c) Using a straight edge or string line, draw a line between front mark & rear mark as shown in *Figure 8*

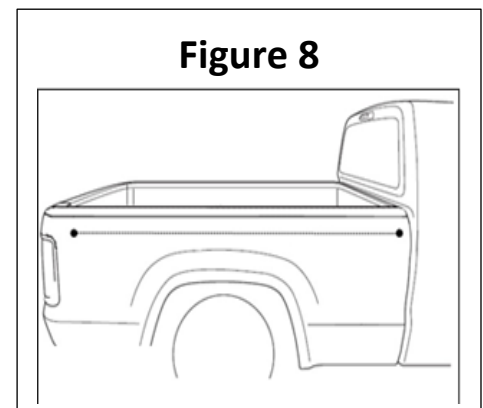

- (d) Fit the **front button only** to the vehicle by drilling a 4mm hole at the front mark then apply rust inhibitor and rivet button into place.

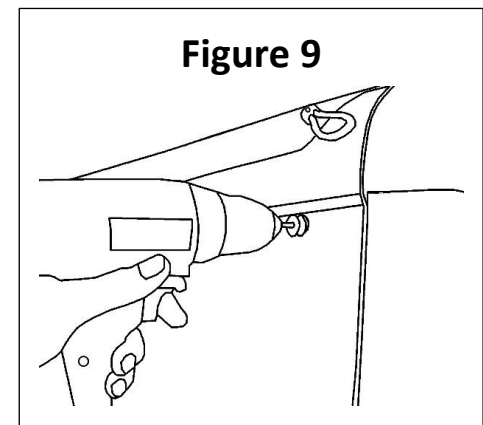

- **Repeat those steps for passenger side.**

- (e) Slide the front of the tonneau cover into the rope track as shown in *Figure 10* and centre the cover. Drape the cover over the cab.

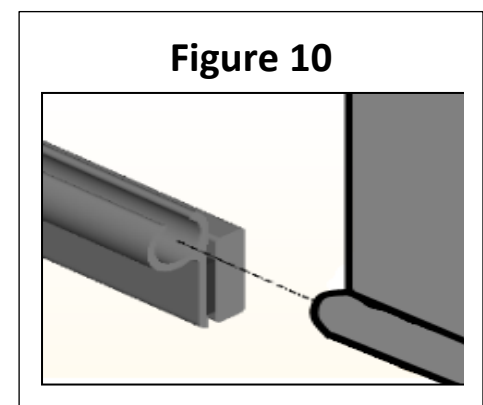

- (f) Install the support bar (Refer Multi Fit Support Bar Page) then drape cover over support bar and fit rear bunji's to buttons on tailgate as shown in **Figure 11**.

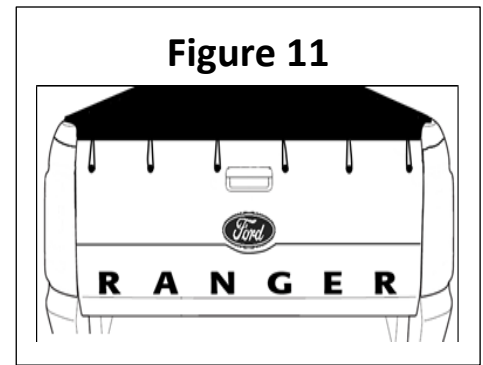

## 5. Fit The Buttons To The Side Tub

- (a) Work from the rear most bunjis towards the front, alternating from side to side.
- (b) Line up the rear most bunji loop (#1) on the driver's side of the vehicle and make a mark on the line drawn in step 4 (c).
- (c) Drill hole, apply rust inhibitor and rivet button into place as shown in **Figure 12**.
- (d) Repeat step 5 (a) to (c) for the rear most bunji loop (#2) on the passenger side of the vehicle.
- (e) Fit remaining 8 bunjis following the sequence as in **Figures 12 & 13**.

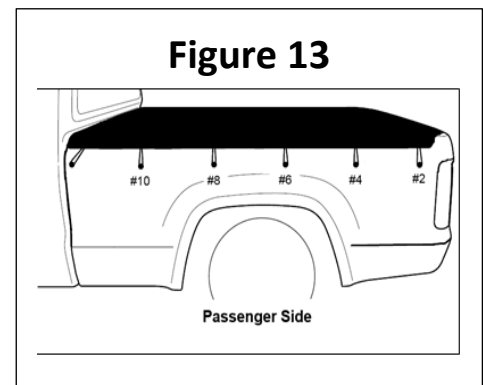
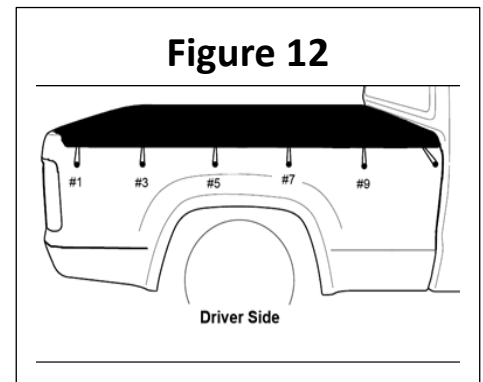

**Note: Ensure you work from side to side to maintain tension across the tonneau cover**

## 6. Fit Seal Tape between Headboard and Tub.

- (a) Cut 2 pieces from the supplied seal tape 270mm long. Use the supplied Seal Template to mark and cut 1 piece to suit the driver's side of the headboard and 1 piece to suit the passenger side of the headboard. **Refer figure 14.**

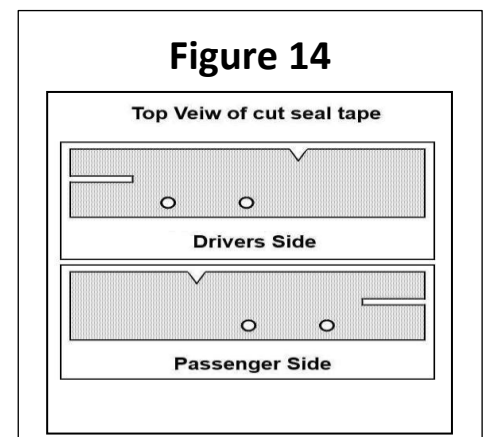

- (b) Partially peel the backing paper from the driver's side seal.
- (c) Align the notched section and the first hole to the vehicle and apply the seal tape to cover the gap between the headboard and the cabin end of the tub. **Refer figure 15**
- (d) Remove the rest of the backing paper and finish applying the seal. Repeat for Passenger side.

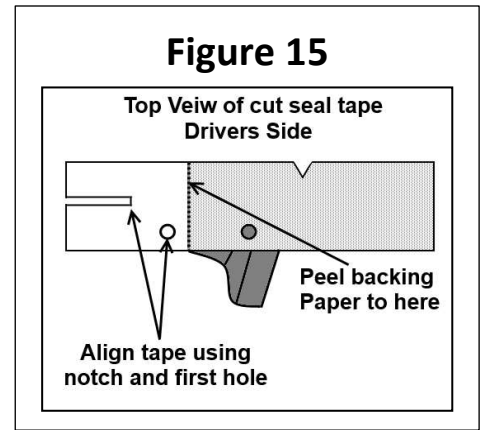

- (e) Use the remainder of the tape to cover the remaining gap between the center section of the headboard and the cabin end of the tub. Overlap the remaining tape evenly at both ends (approx. 30-40mm).

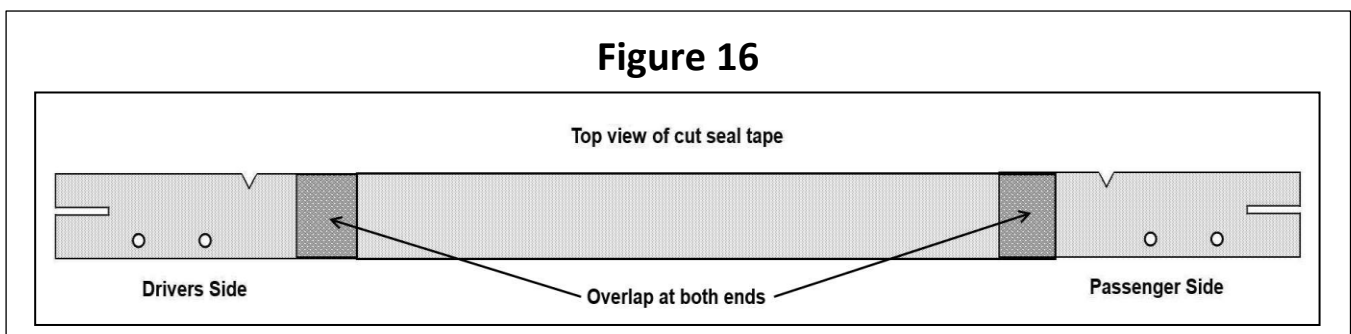

- (f) To Fit Anti-Abrasive Discs: Firstly clean the area behind each bunji head with a clean rag and methyated sprits. Then attach the anti-abrasive discs centrally behind each bunji head.

## 2. TONNO LOCK

The Tonno Lock is now a standard feature included with all Tuff Tonneaus. The Tonno Lock is situated at the front of the tonneau cover, so as not to impede the accessibility of the Tuff Tonneau.

Fitting the lock is simple and only requires a small attachment on the inside edge of the tub behind the cab. Together with a padlock, it provides you with an extremely effective theft deterrent. The Tonno Lock is designed to suit all utes and

prevent thieves stealing your Tuff Tonneau, so you can continue to rely on the Tuff Tonneaus' name to give you what you want in a tonneau cover.



### 2.1 BASIC TOOL REQUIRED

Rivet gun, Drill, Torch, and Marking Pencil/Pen.

You will need to buy a small Padlock- make sure the padlock will go through the hole on the Tonno lock.

## 2.2 TONNO LOCK CONTENTS

- 2 X 4MM Aluminium rivets
- 1 x Tonno Lock bracket

## 2.3 FITTING TONNO LOCK

1. Attach the black lock bracket to the bracket on the tonneau with your padlock, and fit the tarp.
2. Getting under the tarp with a torch, place the lock bracket against the body and mark holes with a pen.
3. Remove tonneau and drill the marks with a 4 mm drill bit, place the lock bracket in position and rivet.

## 3. MULTI-FIT SUPPORT BAR

The Tuff Tonneau Multi - Fit Support Bar is designed to fit almost all Utes on the Market, from Suburu Brumbys to Cab Chassis aluminium trays.

Part No: 300516



### 3.1 BASIC TOOL REQUIRED

Drill, 4mm drill bit

### 3.2 MULTI-FIT SUPPORT BAR CONTENTS

- 1 x hollow bar centrepiece
- 2 x grub screws
- 2 x solid bar end piece
- 1 x Tonneau bar sheath

### 3.3 FITTING MULTI-FIT BAR

1. Insert solid bar pieces into either end of hollow tube. Adjust bar so it fits between bar bracket holders with the holes facing to the ground (so the grub screws don't rub against the tonneau), as shown above and then with a white pencil make a mark through the small holes of the hollow bar onto the solid ends. This is where you will drill a hole to the depth of about 1-2mm (do not go any further)
2. Join the pieces back together and screw grub screws through the hollow bar into the holes that you drilled. **Make sure you do not over tighten the grub screws.** Then place the tonneau sheath over the bar to stop the bar wearing against the tonneau. Refit the bar. You may kink the bar in the middle to give it some extra height to assist with water runoff.



**Warning if you do not fit the tonneau sheath over the bar, the tonneau cover will quickly wear through which is not covered by warranty.**

## **4. WARRANTY AND FEEDBACK**

**Please register your warranty details online at:**

**QR Code:**



**Website Link:**

**<http://www.tto.com.au/en-au/warranty.html>**

**Please complete our 2 minute feedback section as we strive to constantly improve for our customers.**